

# 2PE

## Hydraulic Piston Pump - SAE



### **2PE Pumps have the following advantages ;**

- Compact Design,
- Economical Conception,
- High Power Density,
- High Overall Efficiency,
- High Rotating Speeds,
- High Output Pressure,
- 350 bar Cont. Work. Pressure,
- 400 bar Peak Pressure,
- From 5cc to 130cc,
- Reduced Noise Level,
- Increased Reliability,
- No Drain Line Necessary,
- Smaller Installation Dimensions,
- One Piece Pistons with Piston Rings,
- Special Inlet Fittings & Accesories,
- Simple Change of Direction of Rotation

## **Other Advantages of 2PE**

New frame sizes to meet market requirements.

For use in mobile & industrial and stationary applications areas.

The pump drive shaft bearings are designed to give the service life expected in these areas of operation.

Interchangeable with other bent axis pumps.

40° bent axis design giving high power, small overall dimensions, optimum efficiency and economic design. Flange and shaft designed for direct mounting on truck gearbox PTO's. The fixed displacement bent axis pumps generates a hydraulic fluid flow. It is designed for use in trucks, commercial vehicles and all stationary hydraulic applications. The 2PE is a fixed pump with rotary group in bent-axis design open circuits. Flow is proportional to drive speed and displacement.

For axial piston units with bent-axis design, the Pistons are arranged diagonally with respect to the drive shaft. The pump covers the whole displacement range 5 to 130 cm<sup>3</sup>/rev. The pump has been developed with modern styling and design to satisfy market demand as to designed new generation plate and pistons with give high flow performance, high pressures with high efficiency and very small dimensions.

The pump is available both to DIN and SAE world standards and can be mounted either directly at the gear box or via a drive shaft. If necessary it can also be augmented with a by-pass valve. Other brand bent axis pumps compatible and interchangeable with 2PE bent axis pumps. Refer to the data sheet and order confirmation for the technical data, operating conditions and operating limits of the Hydraulic Piston Pumps.

# Ordering Code of 2PE Pumps

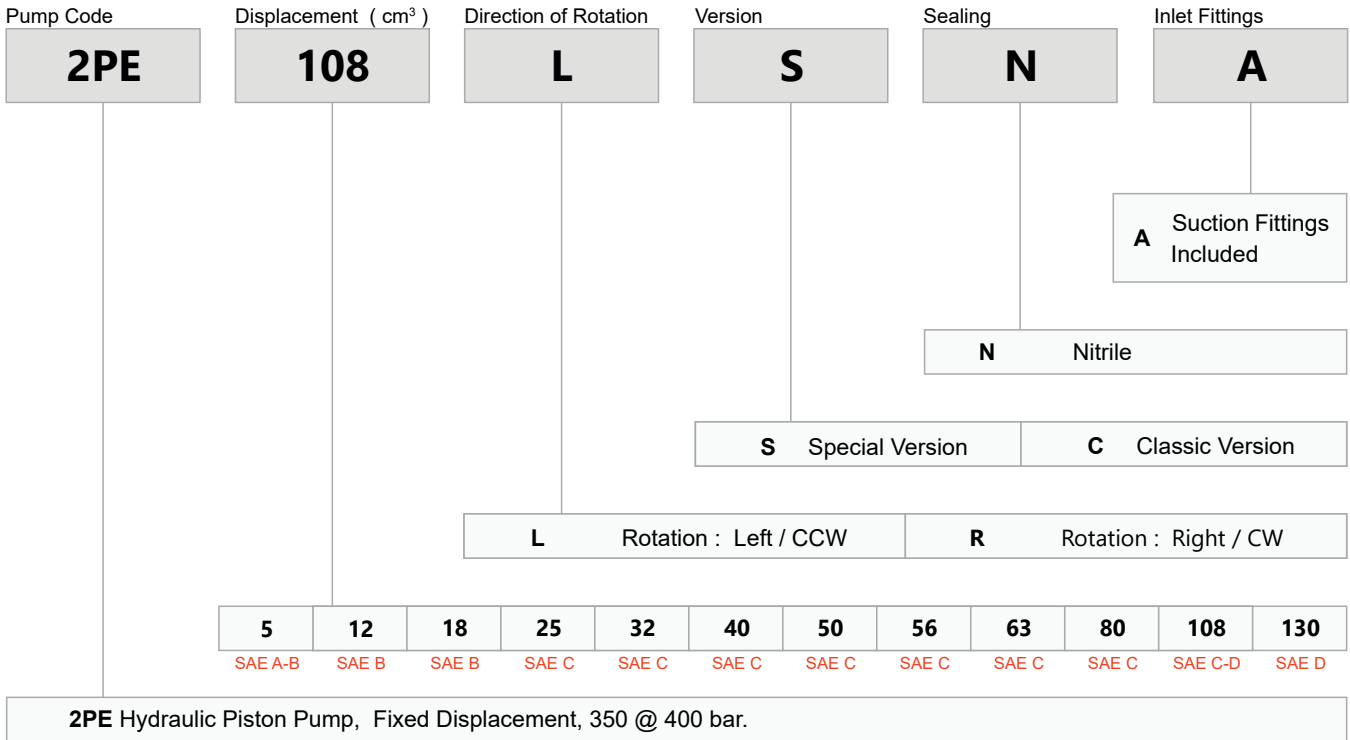

**Special Version ;** Back Cover  
Drive Shaft  
Mounting Flange

Formulas			
<b>Pump Output Flow</b>	GPM	$GPM = (\text{Speed (rpm)} \times \text{disp. (cu. in.)}) / 231$	$GPM = (n \times d) / 231$
<b>Pump Input Horsepower</b>	HP	$HP = GPM \times \text{Pressure (psi)} / 1714 \times \text{Efficiency}$	$HP = (Q \times P) / 1714 \times E$
<b>Pump Efficiency</b>	E	Overall Efficiency = Output HP / Input HP	$E_{\text{overall}} = \text{HP}_{\text{out}} / \text{HP}_{\text{in}} \times 100$
		Overall Efficiency = Volumetric Eff. $\times$ Mechanical Eff.	$E_{\text{overall}} = \text{EffVol.} \times \text{EffMech.}$
<b>Pump Volumetric Efficiency</b>	E	Volumetric Efficiency = Actual Flow Rate Output (GPM) / Theoretical Flow Rate Output (GPM) $\times$ 100	$\text{EffVol.} = Q_{\text{act.}} / Q_{\text{theo.}} \times 100$
<b>Pump Mechanical Efficiency</b>	E	Mechanical Efficiency = Theoretical Torque to Drive / Actual Torque to Drive $\times$ 100	$\text{EffMech} = T_{\text{theo.}} / T_{\text{act.}} \times 100$
<b>Pump Displacement</b>	CIPR	$\text{Displcmnt (In.}^3 \text{ / rev.)} = \text{Flow Rate (GPM)} \times 231 / \text{Pump RPM}$	$\text{CIPR} = \text{GPM} \times 231 / \text{RPM}$
<b>Pump Torque</b>	T	Torque = Horsepower $\times$ 63025 / RPM	$T = 63025 \times \text{HP} / \text{RPM}$
		Torque = Pressure (PSIG) $\times$ Pump Displacement (CIPR) / 2 $\pi$	$T = P \times \text{CIPR} / 6.28$

Horsepower for driving a pump : For every 1 hp of drive, the equivalent of 1 gpm @ 1500 psi can be produced.

Horsepower for idling a pump : To idle a pump when it is unloaded will require about 5% of it's full rated power

Wattage for heating hydraulic oil: Each watt will raise the temperature of 1 gallon of oil by 1° F. per hour.

Flow velocity in hydraulic lines : Pump suction lines 2 to 4 feet per second, pressure lines up to 500 psi - 10 to 15 ft./sec., pressure lines 500 to 3000 psi - 15 to 20 ft./sec.; all oil lines in air-over-oil systems; 4 ft./sec.



# Performance

### Efficiency Curves ( 1000 rpm )

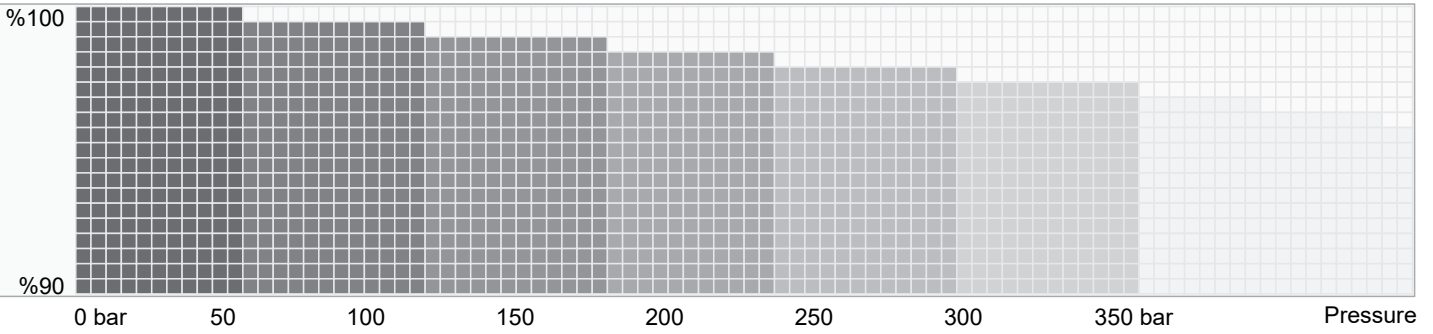

### Torque with Pump Output Pressure

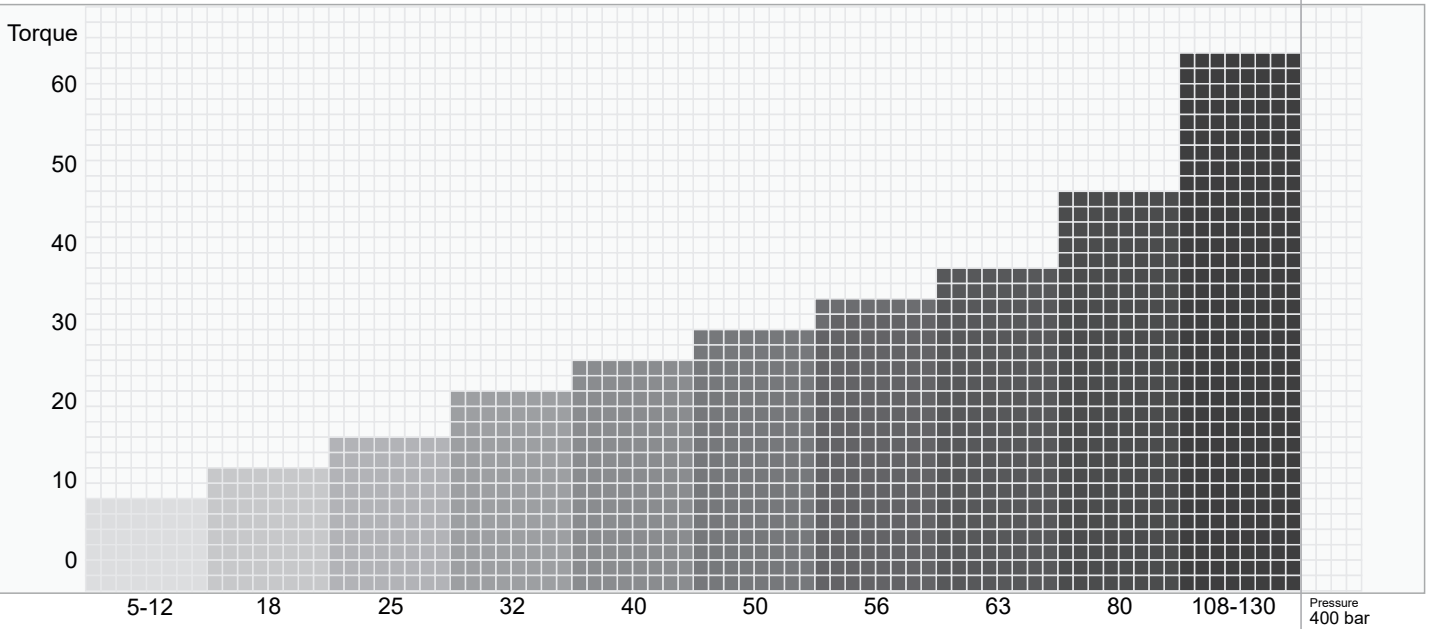

### Flow with Pump Speed

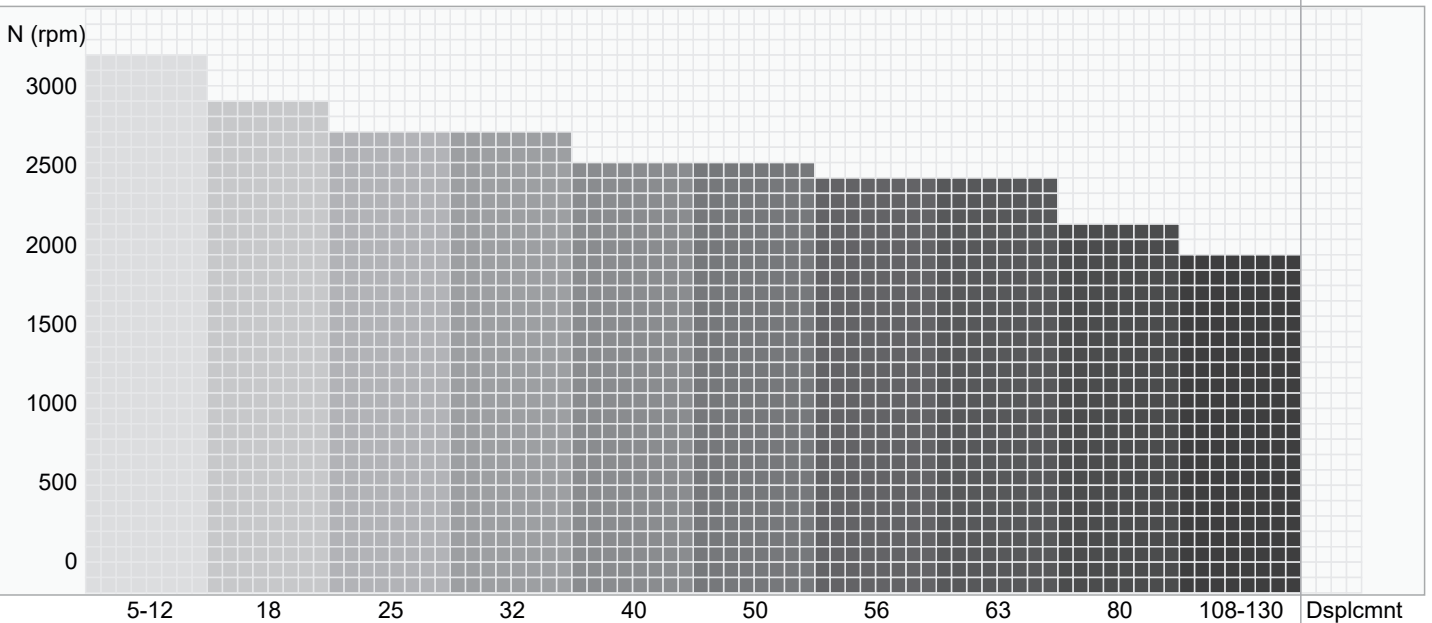

# 2PE 12 - SAE B - 2 BOLT

## SAE B 7/8" 13T-16/32DP

### SAE B - 2 BOLT MOUNTING (SAE J744)

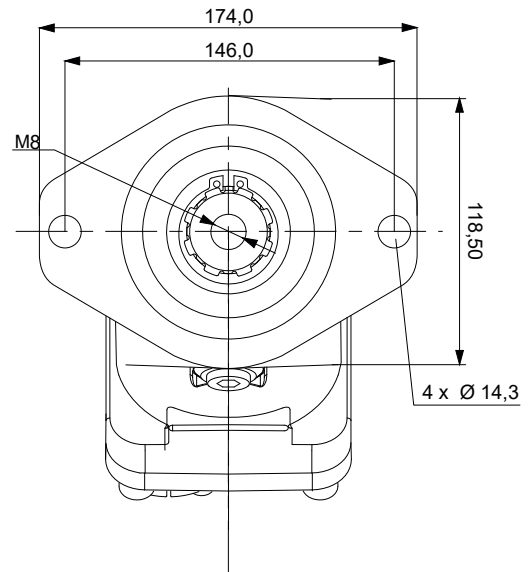
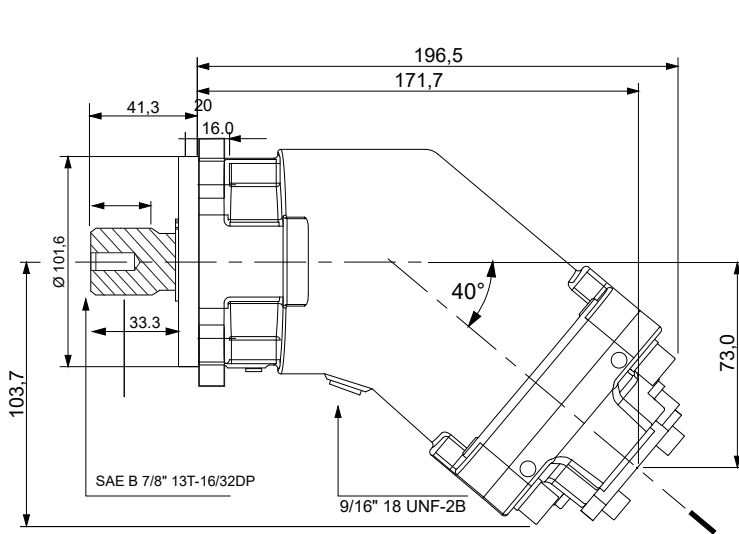

### Spline Shaft

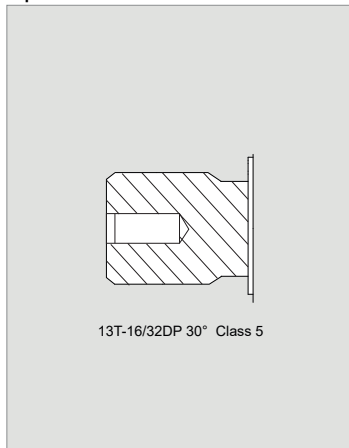

### Keyed Shaft

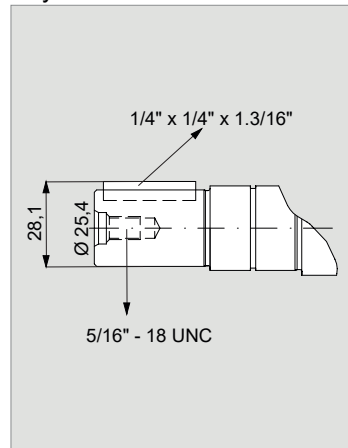

### Back Cover

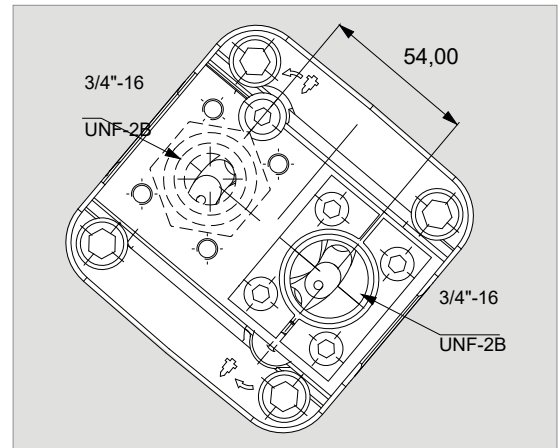

<b>x 1000 rpm</b>	12,00 cc
<b>x 1500 rpm</b>	18,00 cc
<b>Max. Continuous Pump Speed</b>	2300 rpm
<b>Max. Limited Pump Speed</b>	3100 rpm
<b>Max. Continuous Pressure</b>	350 bar
<b>Max. Intermit. Peak Pressure</b>	400 bar
<b>Max. Torque at 350 bar</b>	71 Nm
<b>Weight without inlet fitting</b>	10,00 kg
<b>Weight with inlet fitting</b>	10,40 kg
<b>Rotation</b>	CW-CCW

### Flow, Speed, Pressure List of 2PE 12

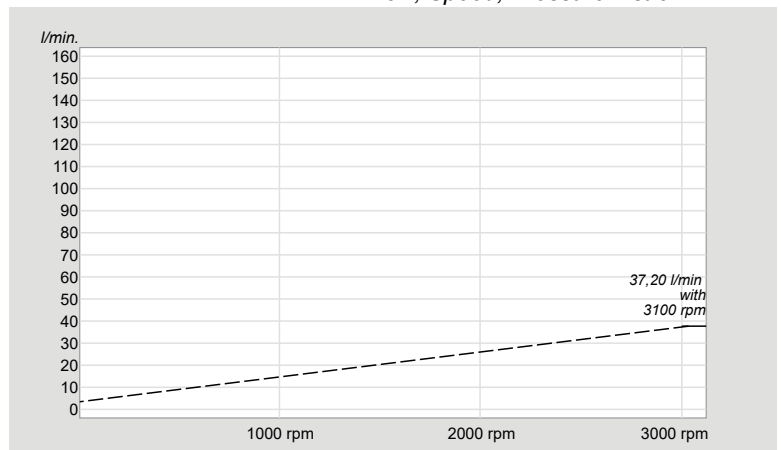

# 2PE 12 - SAE B - 6 BOLT

## SAE B 7/8" 13T-16/32DP

### SAE B - 6 BOLT MOUNTING (SAE J744)

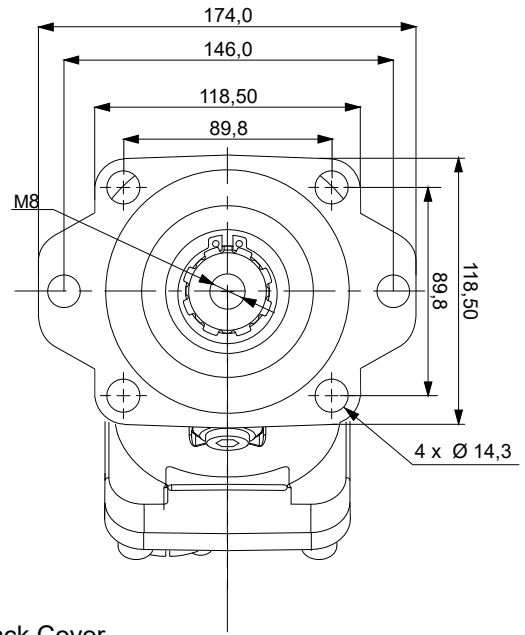
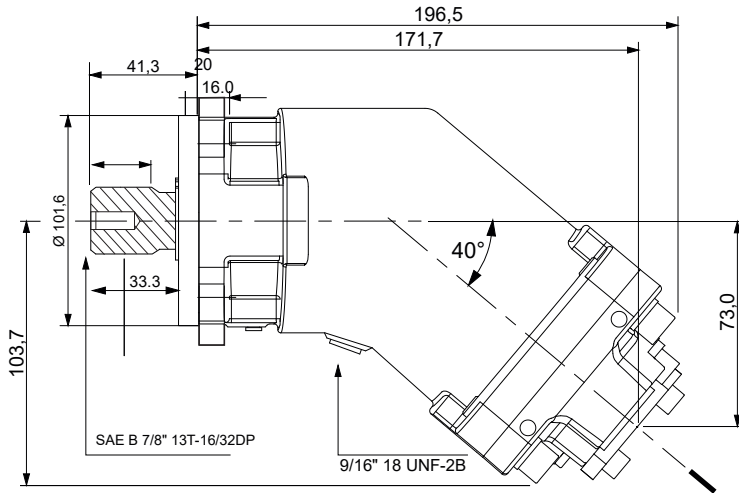

### Spline Shaft

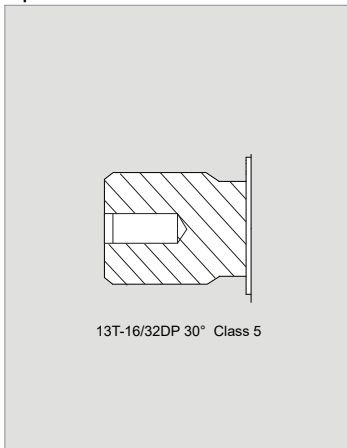

### Keyed Shaft

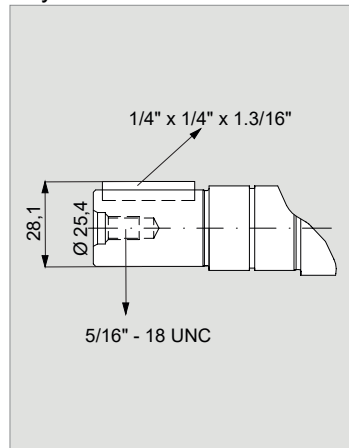

### Back Cover

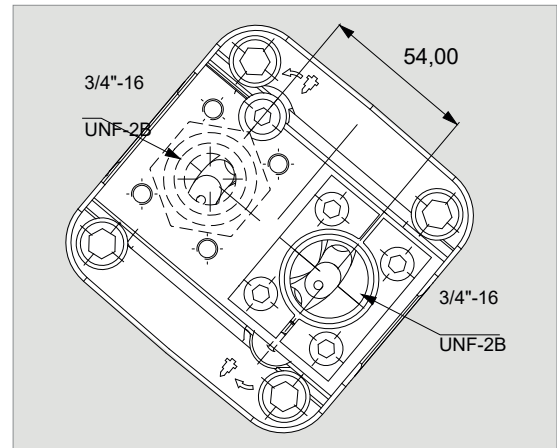

### Flow, Speed, Pressure List of 2PE 12

<b>x 1000 rpm</b>	12,00 cc
<b>x 1500 rpm</b>	18,00 cc
<b>Max. Continuous Pump Speed</b>	2300 rpm
<b>Max. Limited Pump Speed</b>	3100 rpm
<b>Max. Continuous Pressure</b>	350 bar
<b>Max. Intermit. Peak Pressure</b>	400 bar
<b>Max. Torque at 350 bar</b>	71 Nm
<b>Weight without inlet fitting</b>	10,00 kg
<b>Weight with inlet fitting</b>	10,40 kg
<b>Rotation</b>	CW-CCW

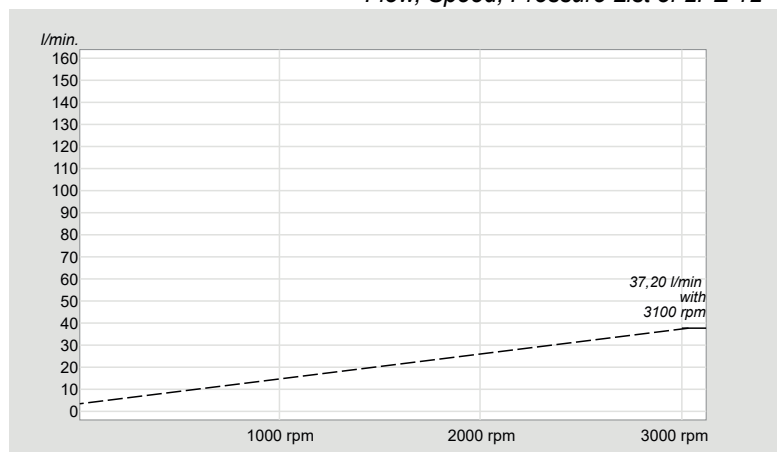

# 2PE 18 - SAE B - 2 BOLT

## SAE B 7/8" 13T-16/32DP

### SAE B - 2 BOLT MOUNTING (SAE J744)

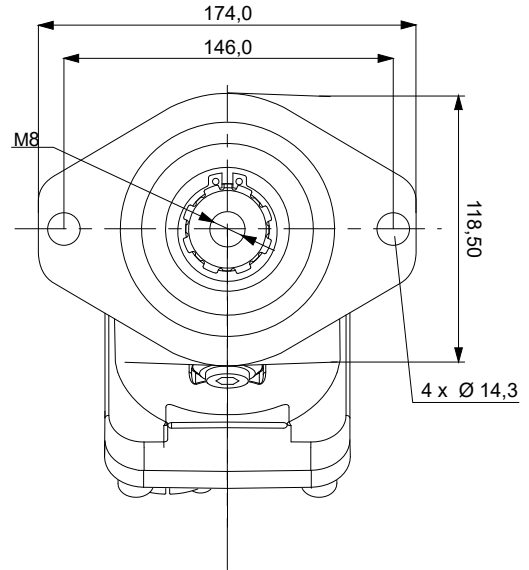
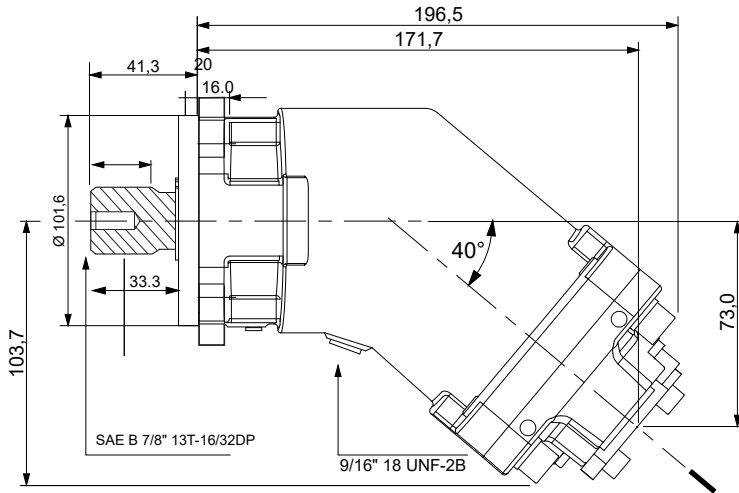

### Spline Shaft

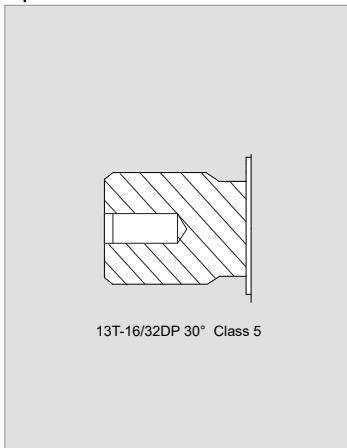

### Keyed Shaft

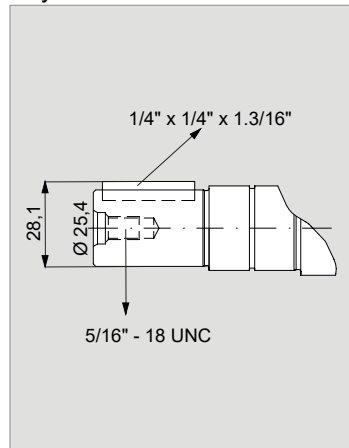

### Back Cover

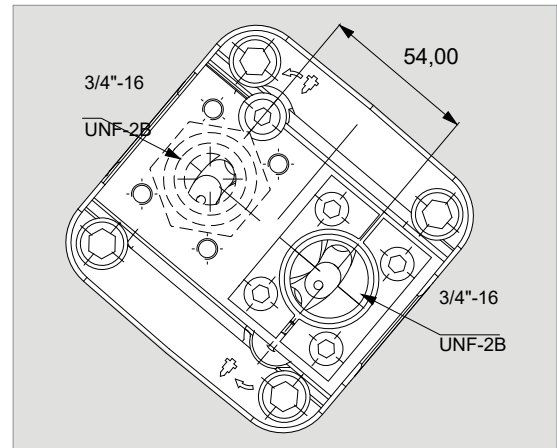

### Flow, Speed, Pressure List of 2PE 18

<b>x 1000 rpm</b>	18,00 cc
<b>x 1500 rpm</b>	27,00 cc
<b>Max. Continuous Pump Speed</b>	2300 rpm
<b>Max. Limited Pump Speed</b>	2900 rpm
<b>Max. Continuous Pressure</b>	350 bar
<b>Max. Intermit. Peak Pressure</b>	400 bar
<b>Max. Torque at 350 bar</b>	105 Nm
<b>Weight without inlet fitting</b>	10,00 kg
<b>Weight with inlet fitting</b>	10,40 kg
<b>Rotation</b>	CW-CCW

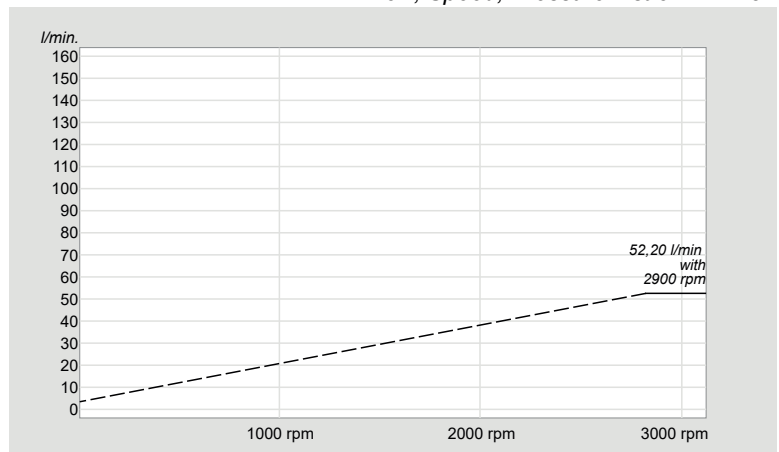



# 2PE 18 - SAE B - 6 BOLT

## SAE B 7/8" 13T-16/32DP

### SAE B - 6 BOLT MOUNTING (SAE J744)

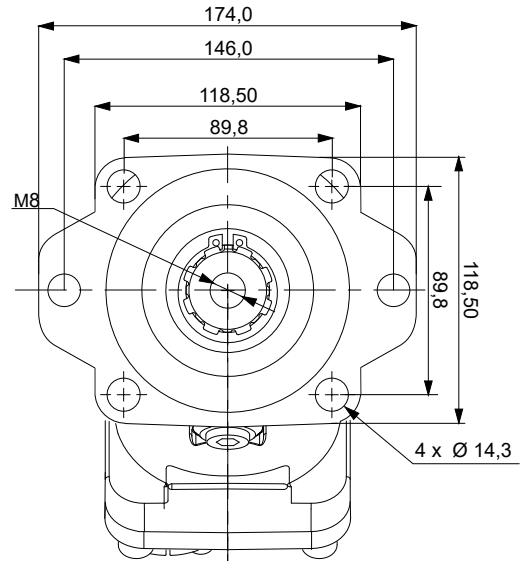
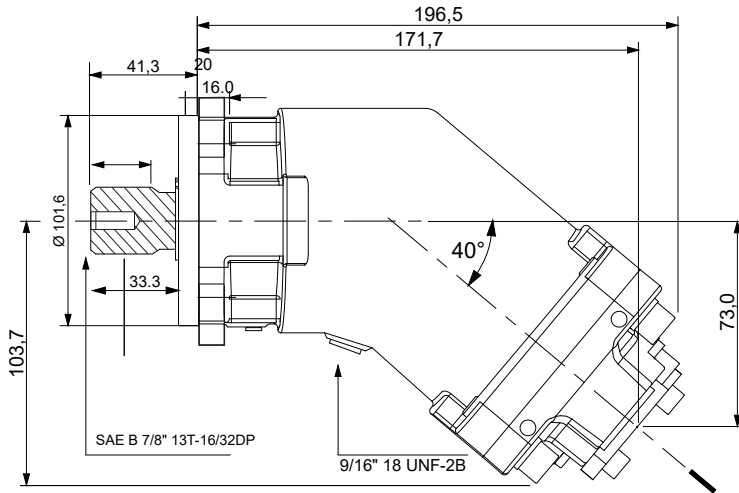

### Spline Shaft

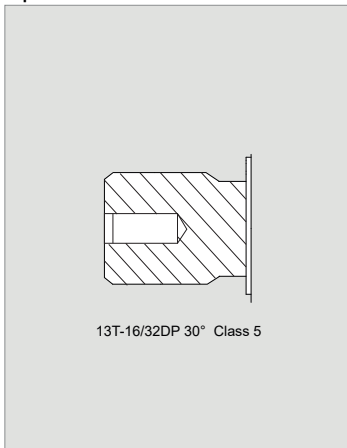

### Keyed Shaft

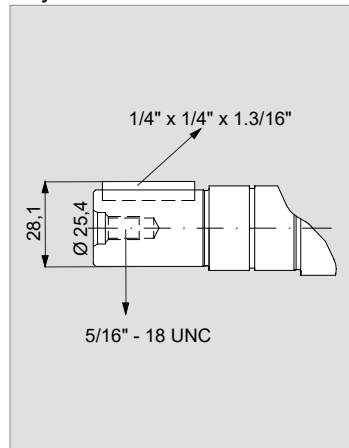

### Back Cover

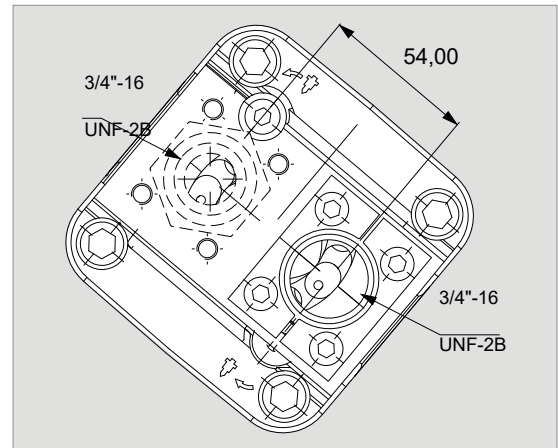

### Flow, Speed, Pressure List of 2PE 18

<b>x 1000 rpm</b>	18,00 cc
<b>x 1500 rpm</b>	27,00 cc
<b>Max. Continuous Pump Speed</b>	2300 rpm
<b>Max. Limited Pump Speed</b>	2900 rpm
<b>Max. Continuous Pressure</b>	350 bar
<b>Max. Intermit. Peak Pressure</b>	400 bar
<b>Max. Torque at 350 bar</b>	105 Nm
<b>Weight without inlet fitting</b>	10,00 kg
<b>Weight with inlet fitting</b>	10,40 kg
<b>Rotation</b>	CW-CCW

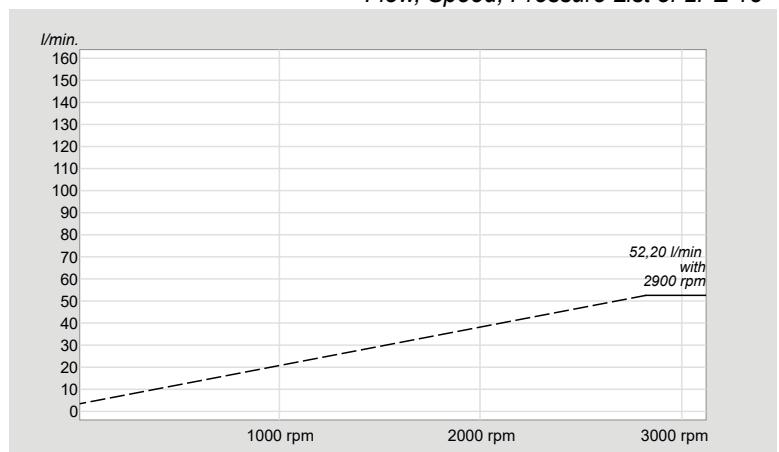

# 2PE 25 - SAE C - 4 BOLT

SAE B 7/8" 13T-16/32DP

## SAE C - 4 BOLT MOUNTING (SAE J744)

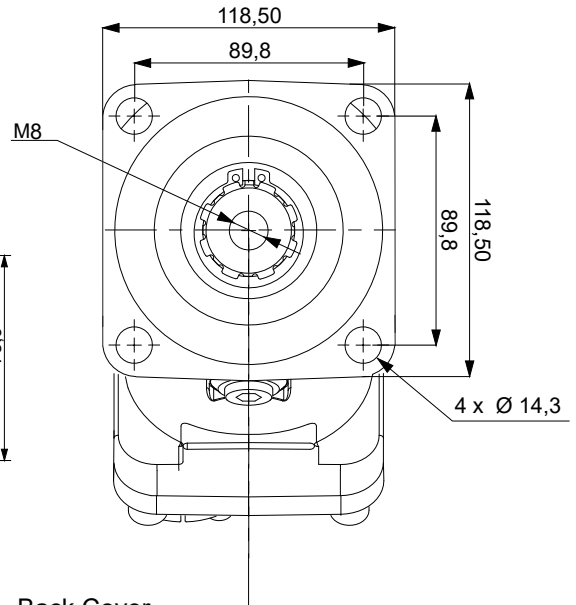
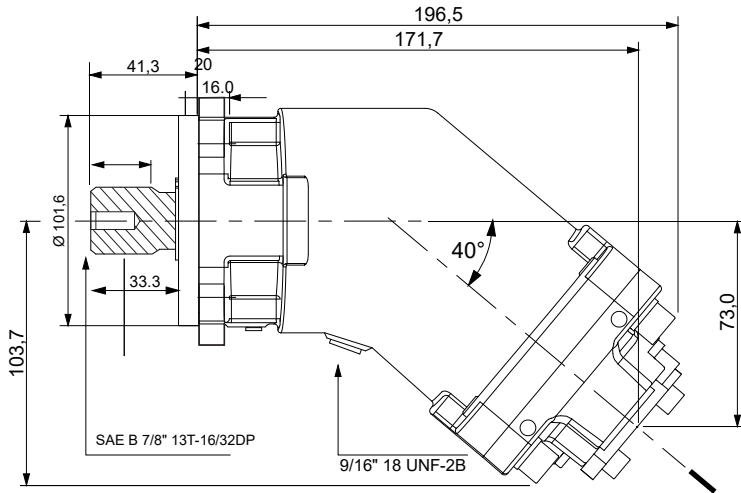

### Spline Shaft

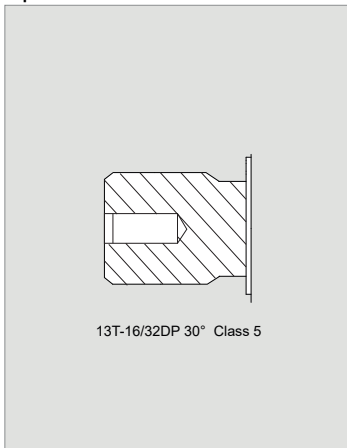

### Keyed Shaft

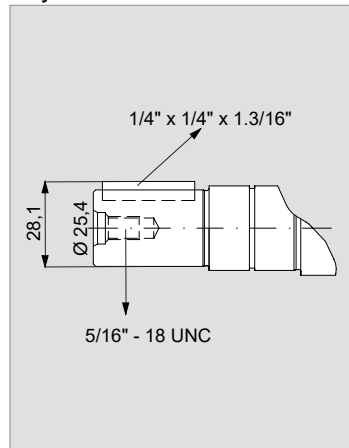

### Back Cover

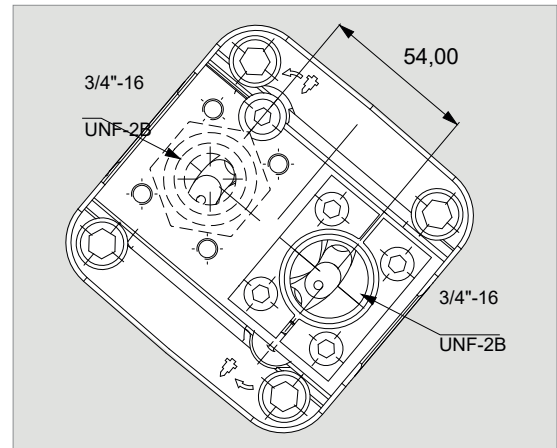

Flow, Speed, Pressure List of 2PE 25

<b>x 1000 rpm</b>	25,00 cc
<b>x 1500 rpm</b>	37,50 cc
<b>Max. Continuous Pump Speed</b>	2300 rpm
<b>Max. Limited Pump Speed</b>	2700 rpm
<b>Max. Continuous Pressure</b>	350 bar
<b>Max. Intermit. Peak Pressure</b>	400 bar
<b>Max. Torque at 350 bar</b>	146 Nm
<b>Weight without inlet fitting</b>	10,50 kg
<b>Weight with inlet fitting</b>	10,90 kg
<b>Rotation</b>	CW-CCW

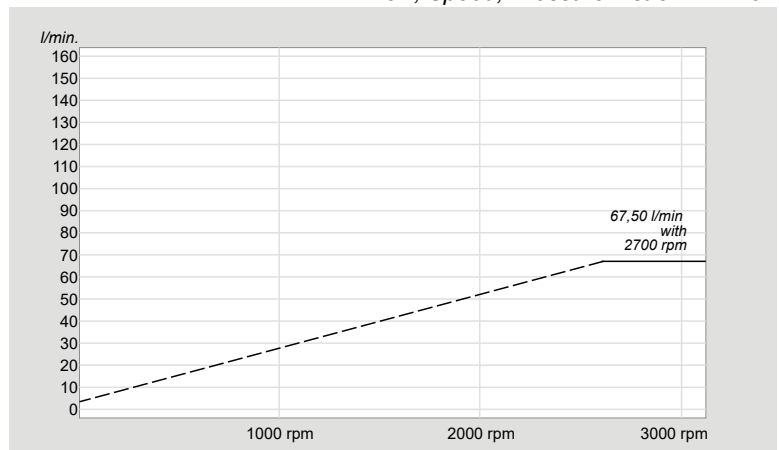

# 2PE 32 - SAE C - 4 BOLT

SAE B 7/8" 13T-16/32DP

## SAE C - 4 BOLT MOUNTING (SAE J744)

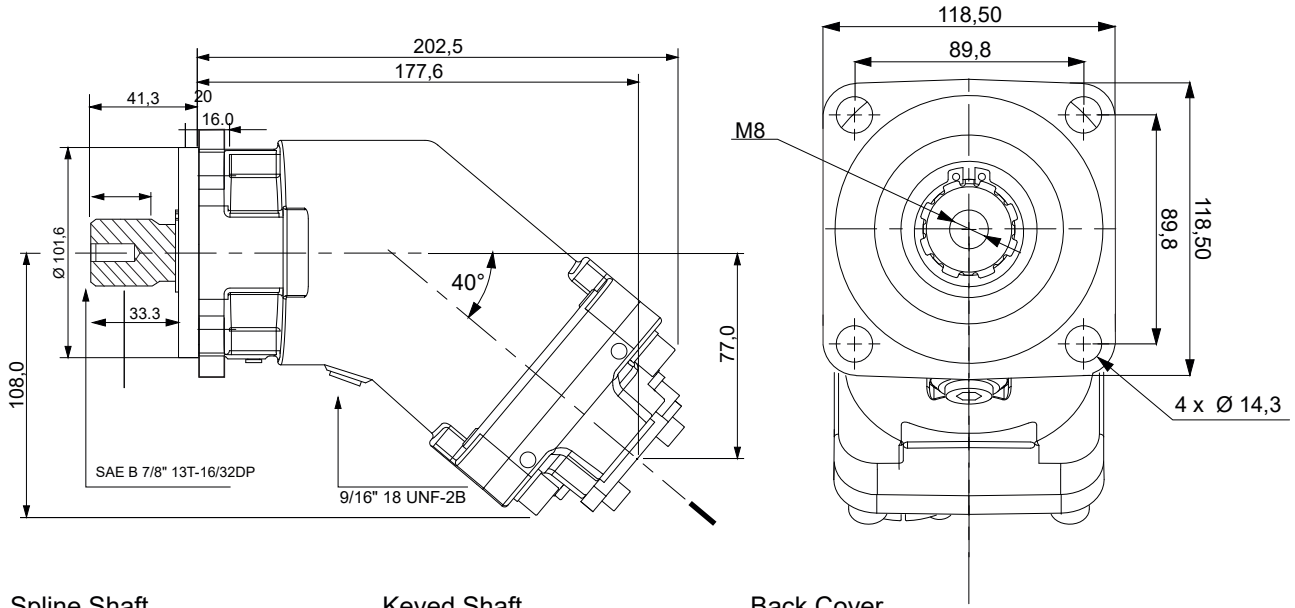

### Spline Shaft

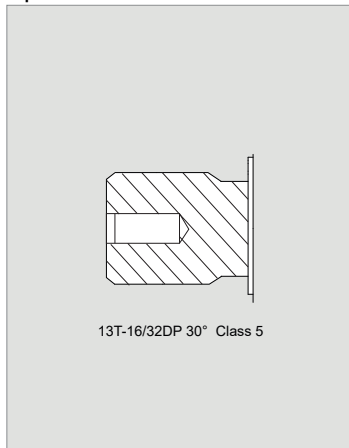

### Keyed Shaft

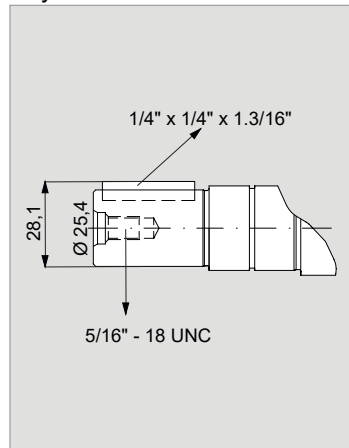

### Back Cover

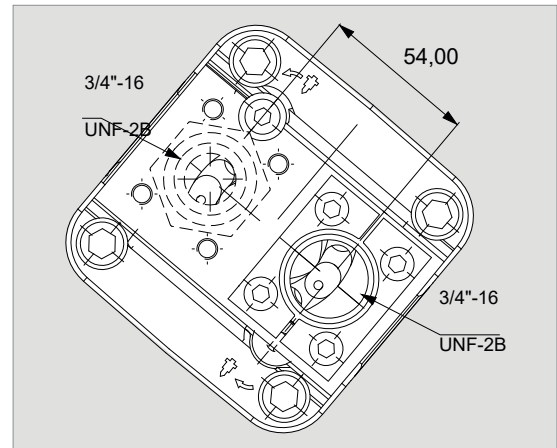

Flow, Speed, Pressure List of 2PE 32

<b>x 1000 rpm</b>	32,00 cc
<b>x 1500 rpm</b>	48,00 cc
<b>Max. Continuous Pump Speed</b>	2250 rpm
<b>Max. Limited Pump Speed</b>	2700 rpm
<b>Max. Continuous Pressure</b>	350 bar
<b>Max. Intermit. Peak Pressure</b>	400 bar
<b>Max. Torque at 350 bar</b>	190 Nm
<b>Weight without inlet fitting</b>	11,50 kg
<b>Weight with inlet fitting</b>	11,90 kg
<b>Rotation</b>	CW-CCW

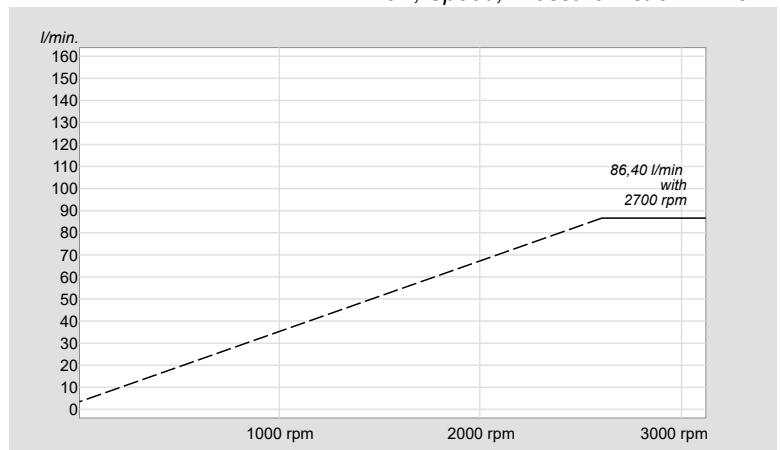

# 2PE 40 - SAE C - 4 BOLT

SAE B 7/8" 13T-16/32DP

## SAE C - 4 BOLT MOUNTING (SAE J744)

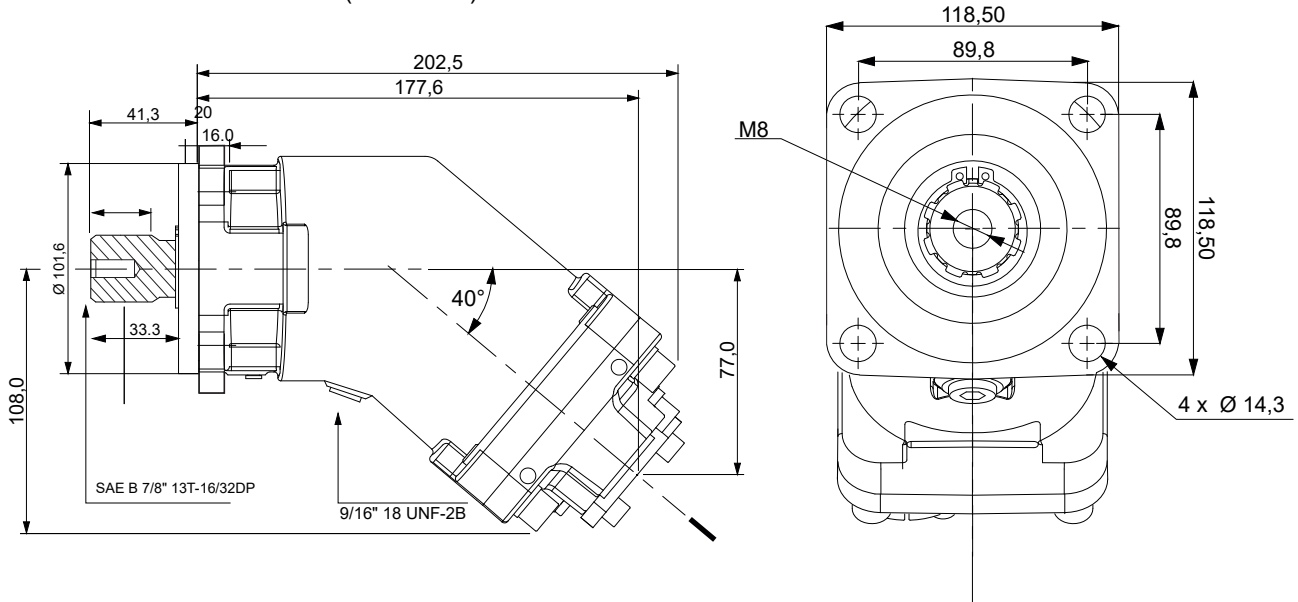

### Spline Shaft

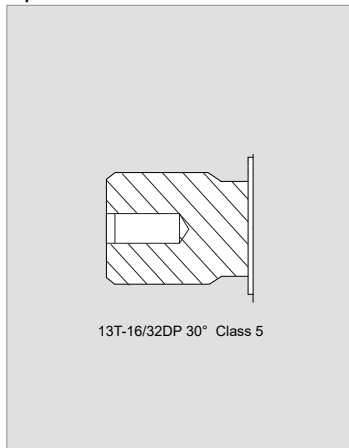

### Keyed Shaft

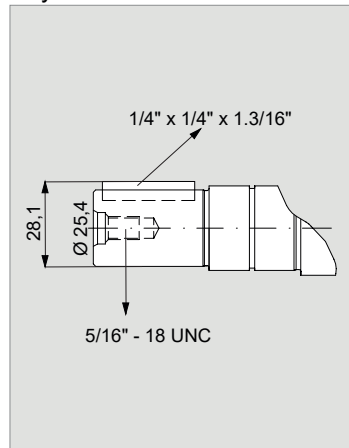

### Back Cover

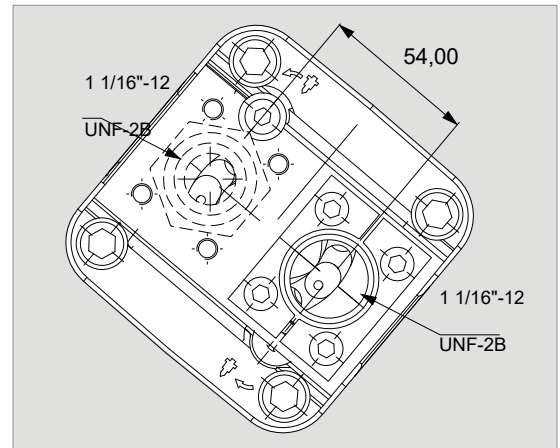

<b>x 1000 rpm</b>	40,20 cc
<b>x 1500 rpm</b>	60,30 cc
<b>Max. Continuous Pump Speed</b>	1900 rpm
<b>Max. Limited Pump Speed</b>	2500 rpm
<b>Max. Continuous Pressure</b>	350 bar
<b>Max. Intermit. Peak Pressure</b>	400 bar
<b>Max. Torque at 350 bar</b>	240 Nm
<b>Weight without inlet fitting</b>	11,50 kg
<b>Weight with inlet fitting</b>	11,90 kg
<b>Rotation</b>	CW-CCW

Flow, Speed, Pressure List of 2PE 40

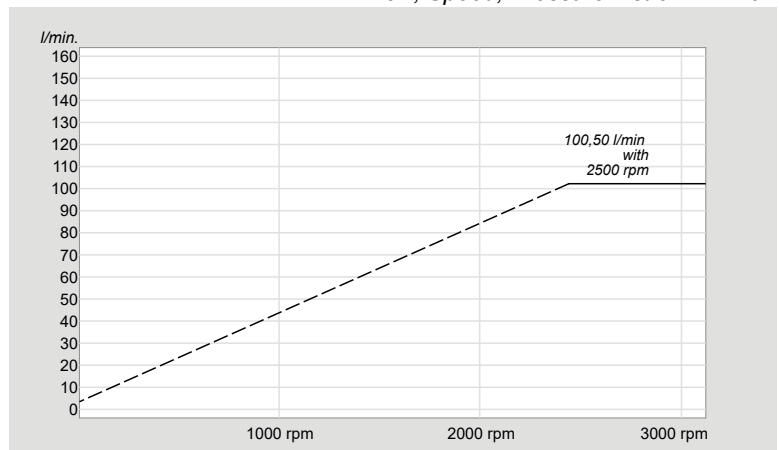

# 2PE 50 - SAE C - 4 BOLT

SAE B 7/8" 13T-16/32DP  
SAE BB 1" 15T-16/32DP

## SAE C - 4 BOLT MOUNTING (SAE J744)

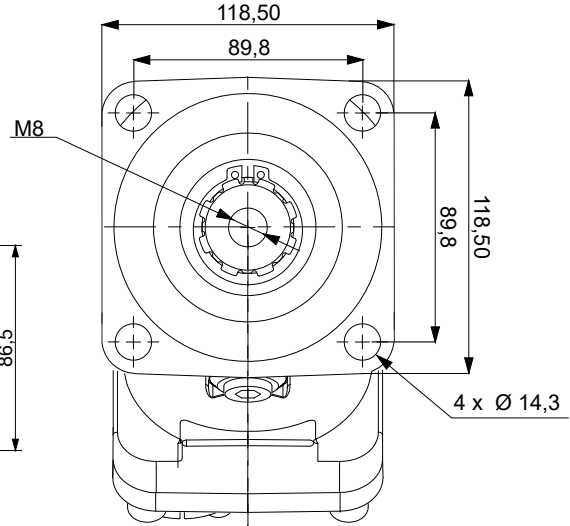
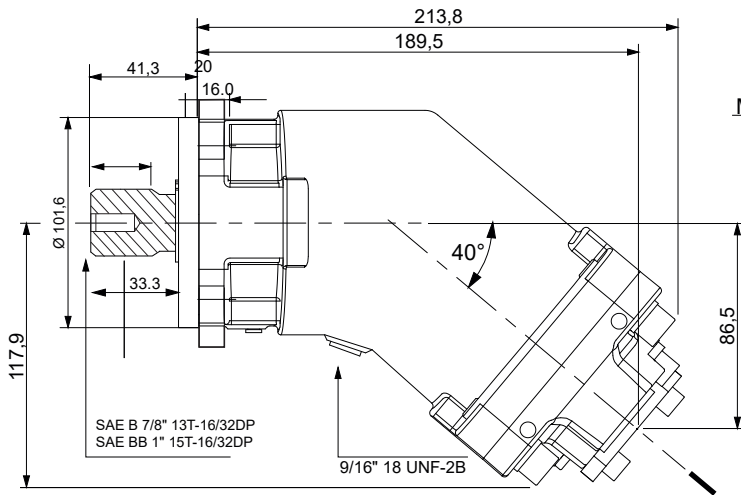

### Spline Shaft

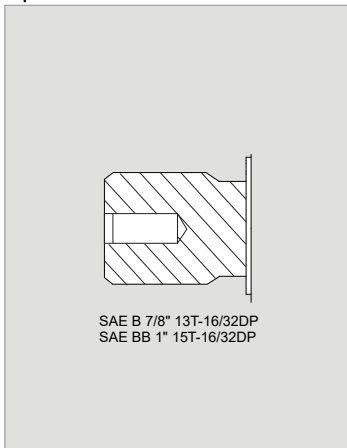

### Keyed Shaft

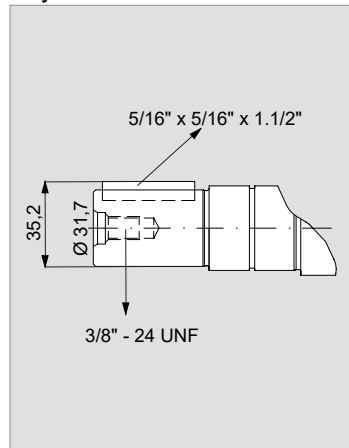

### Back Cover

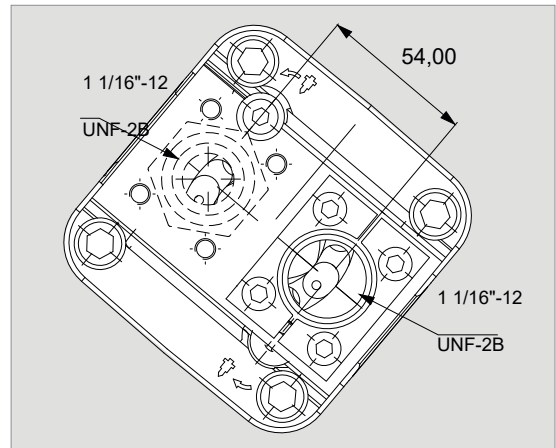

## Flow, Speed, Pressure List of 2PE 50

<b>x 1000 rpm</b>	50,00 cc
<b>x 1500 rpm</b>	75,00 cc
<b>Max. Continuous Pump Speed</b>	1900 rpm
<b>Max. Limited Pump Speed</b>	2500 rpm
<b>Max. Continuous Pressure</b>	350 bar
<b>Max. Intermit. Peak Pressure</b>	400 bar
<b>Max. Torque at 350 bar</b>	292 Nm
<b>Weight without inlet fitting</b>	12,00 kg
<b>Weight with inlet fitting</b>	12,40 kg
<b>Rotation</b>	CW-CCW

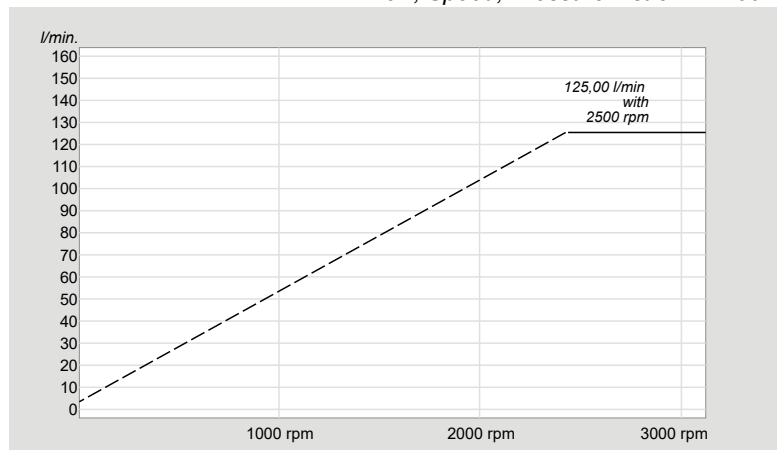

# 2PE 63 - SAE C - 4 BOLT

SAE B 7/8" 13T-16/32DP  
SAE BB 1" 15T-16/32DP

## SAE C - 4 BOLT MOUNTING (SAE J744)

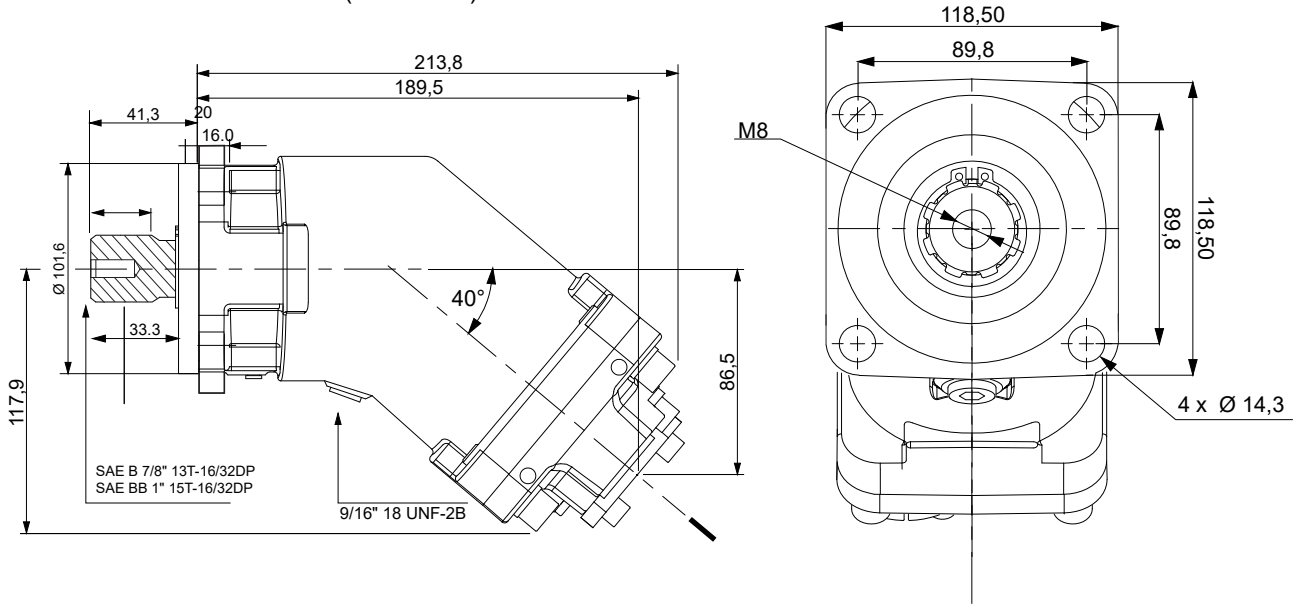

### Spline Shaft

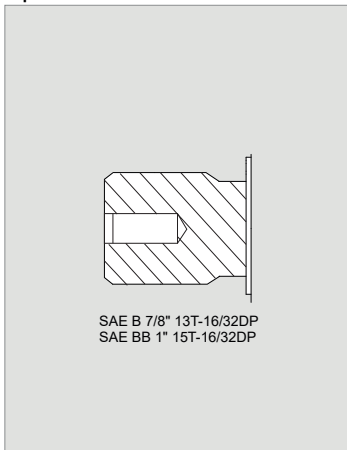

### Keyed Shaft

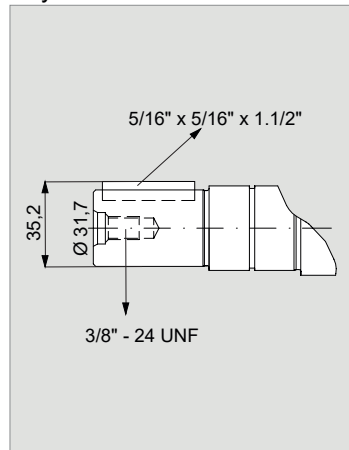

### Back Cover

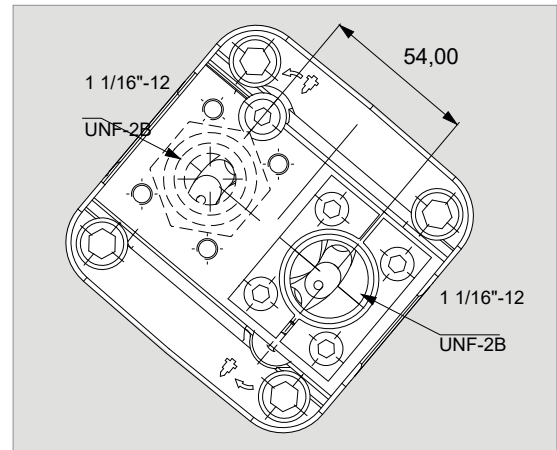

Flow, Speed, Pressure List of 2PE 63

<b>x 1000 rpm</b>	63,00 cc
<b>x 1500 rpm</b>	94,50 cc
<b>Max. Continuous Pump Speed</b>	1900 rpm
<b>Max. Limited Pump Speed</b>	2300 rpm
<b>Max. Continuous Pressure</b>	350 bar
<b>Max. Intermit. Peak Pressure</b>	400 bar
<b>Max. Torque at 350 bar</b>	360 Nm
<b>Weight without inlet fitting</b>	12,50 kg
<b>Weight with inlet fitting</b>	12,90 kg
<b>Rotation</b>	CW-CCW

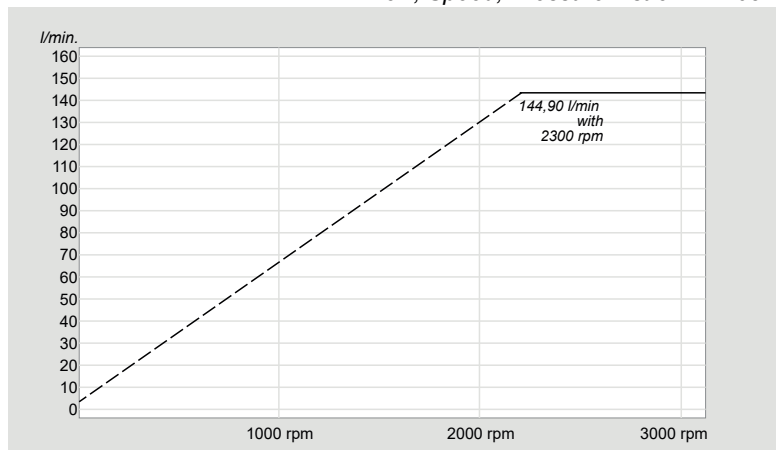

# 2PE 80 - SAE C - 4 BOLT

SAE D 13T-8/16  
SAE C 14T-12/24

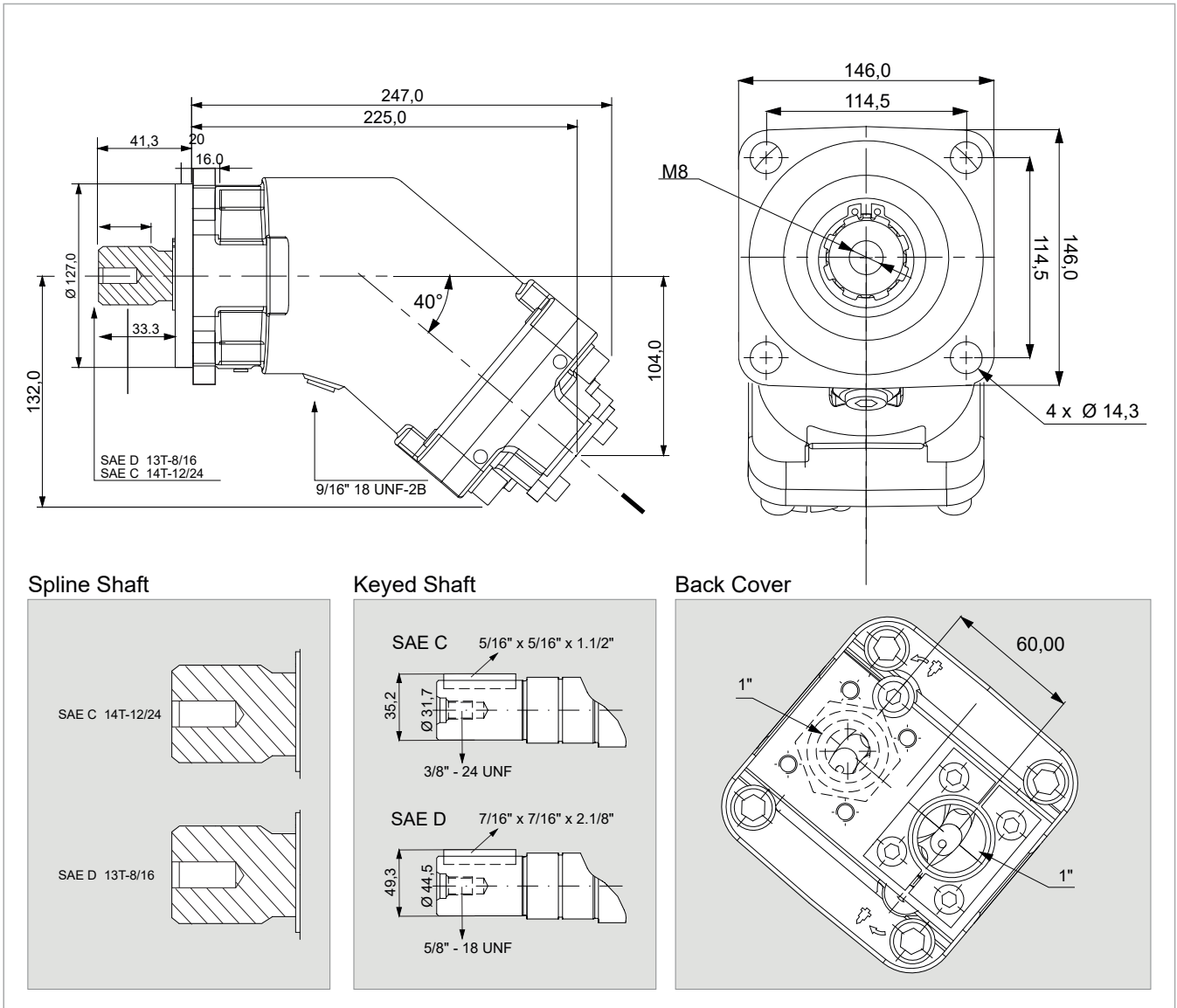

<b>x 1000 rpm</b>	80,00 cc
<b>x 1500 rpm</b>	120,00 cc
<b>Max. Continuous Pump Speed</b>	1700 rpm
<b>Max. Limited Pump Speed</b>	2100 rpm
<b>Max. Continuous Pressure</b>	350 bar
<b>Max. Intermit. Peak Pressure</b>	400 bar
<b>Max. Torque at 350 bar</b>	460 Nm
<b>Weight without inlet fitting</b>	16,00 kg
<b>Weight with inlet fitting</b>	16,40 kg
<b>Rotation</b>	CW-CCW

Flow, Speed, Pressure List of 2PE 80

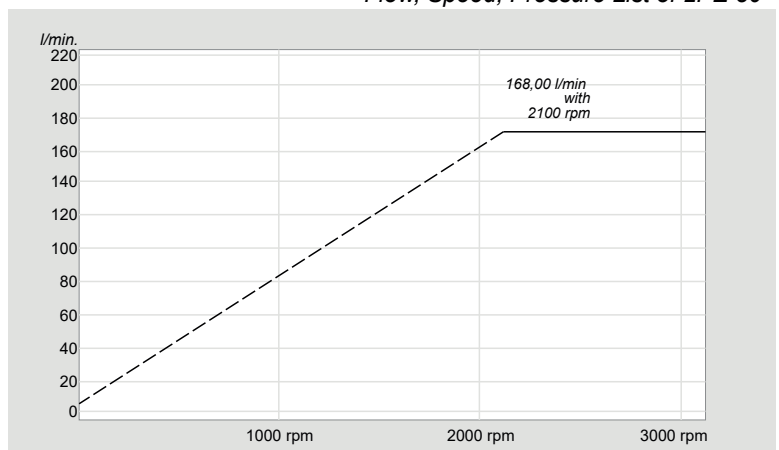

# 2PE 108 - SAE C - 4 BOLT

SAE D 13T-8/16  
SAE C 14T-12/24

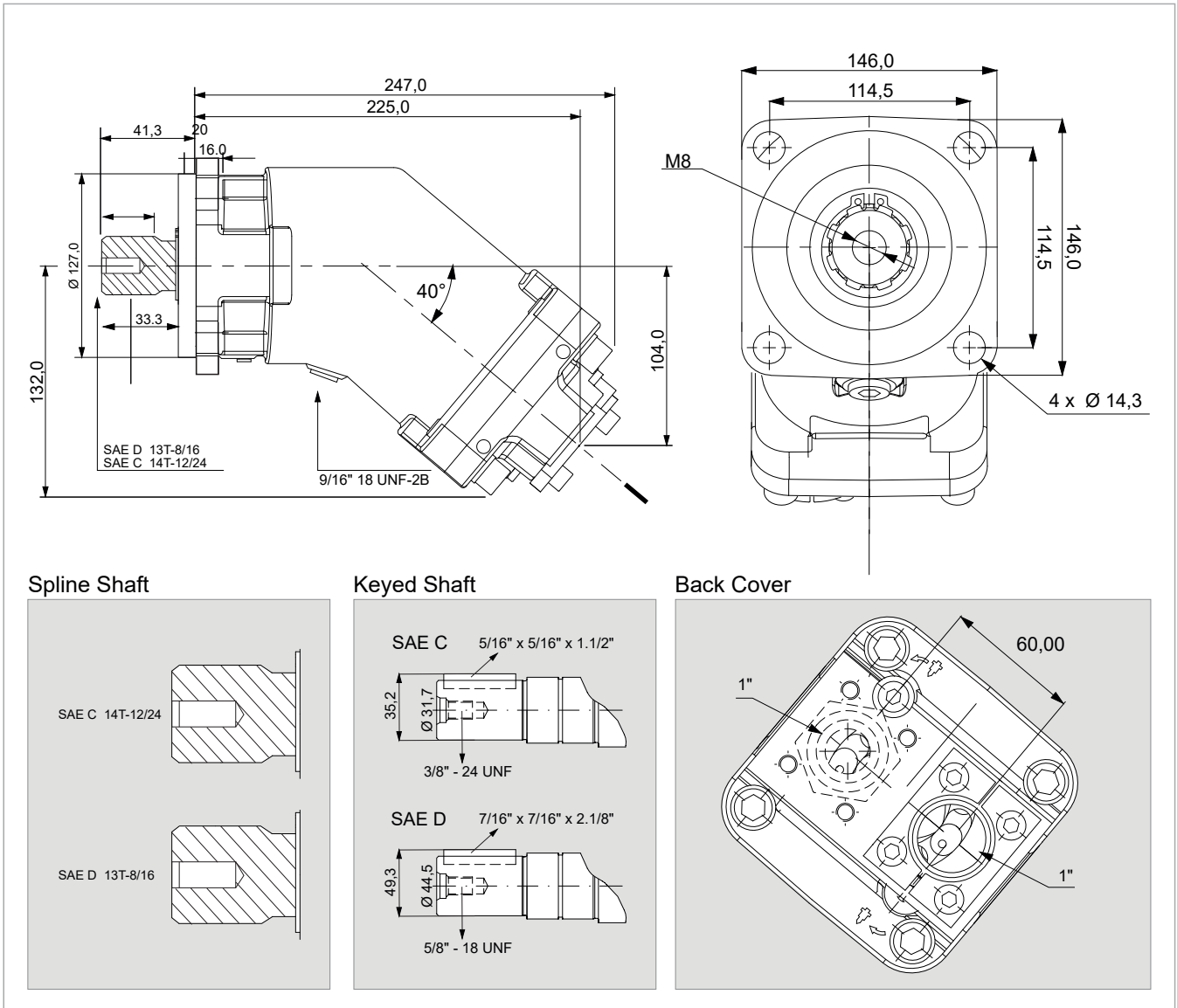

<b>x 1000 rpm</b>	108,40 cc
<b>x 1500 rpm</b>	162,60 cc
<b>Max. Continuous Pump Speed</b>	1700 rpm
<b>Max. Limited Pump Speed</b>	1900 rpm
<b>Max. Continuous Pressure</b>	350 bar
<b>Max. Intermit. Peak Pressure</b>	400 bar
<b>Max. Torque at 350 bar</b>	620 Nm
<b>Weight without inlet fitting</b>	16,50 kg
<b>Weight with inlet fitting</b>	16,90 kg
<b>Rotation</b>	CW-CCW

Flow, Speed, Pressure List of 2PE 108

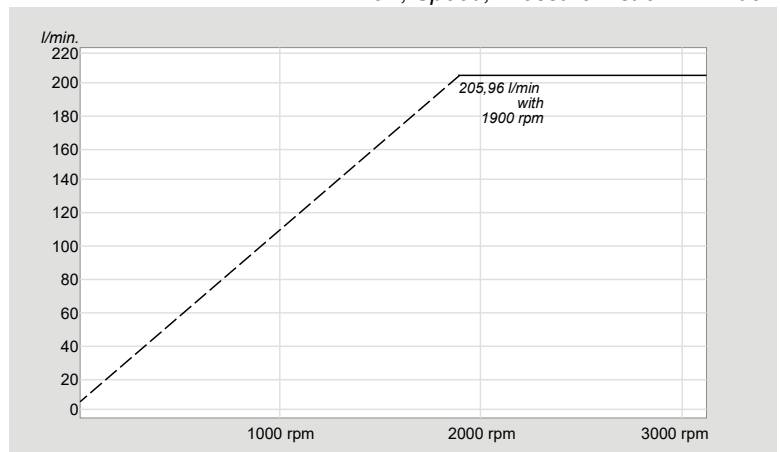



# 2PE 108 - SAE D - 4 BOLT

SAE D 13T-8/16  
SAE C 14T-12/24

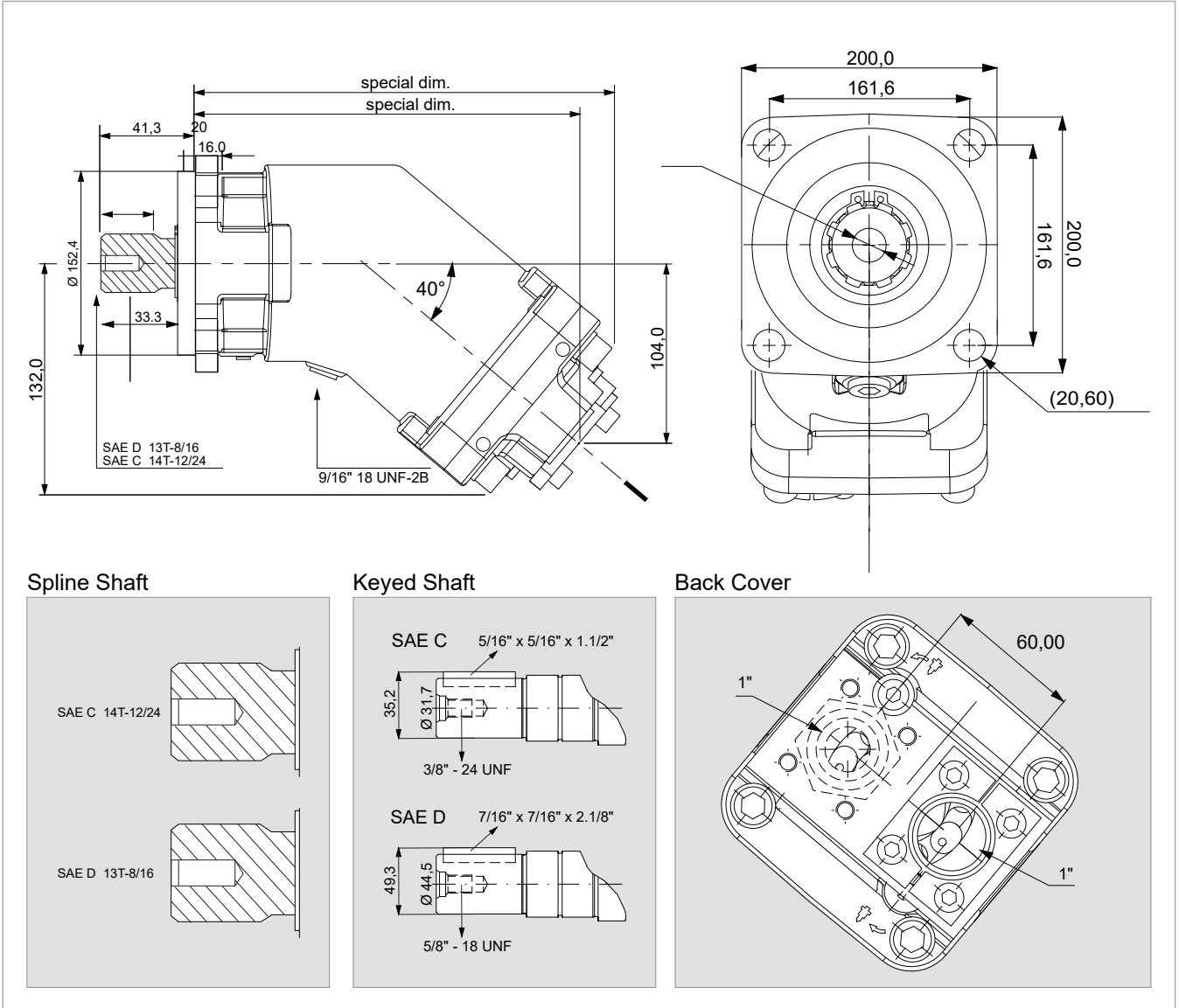

Spline Shaft

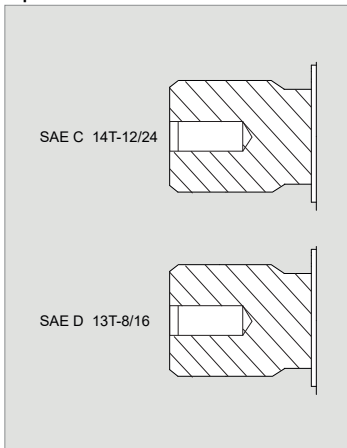

Keyed Shaft

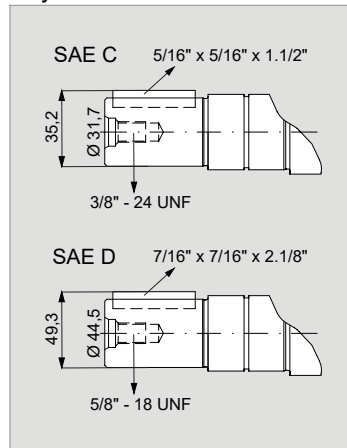

Back Cover

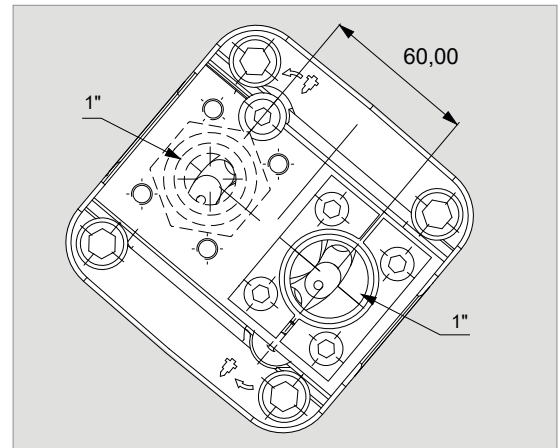

Flow, Speed, Pressure List of 2PE 108

<b>x 1000 rpm</b>	108,40 cc
<b>x 1500 rpm</b>	162,60 cc
<b>Max. Continuous Pump Speed</b>	1700 rpm
<b>Max. Limited Pump Speed</b>	1900 rpm
<b>Max. Continuous Pressure</b>	350 bar
<b>Max. Intermit. Peak Pressure</b>	400 bar
<b>Max. Torque at 350 bar</b>	620 Nm
<b>Weight without inlet fitting</b>	16,50 kg
<b>Weight with inlet fitting</b>	16,90 kg
<b>Rotation</b>	CW-CCW

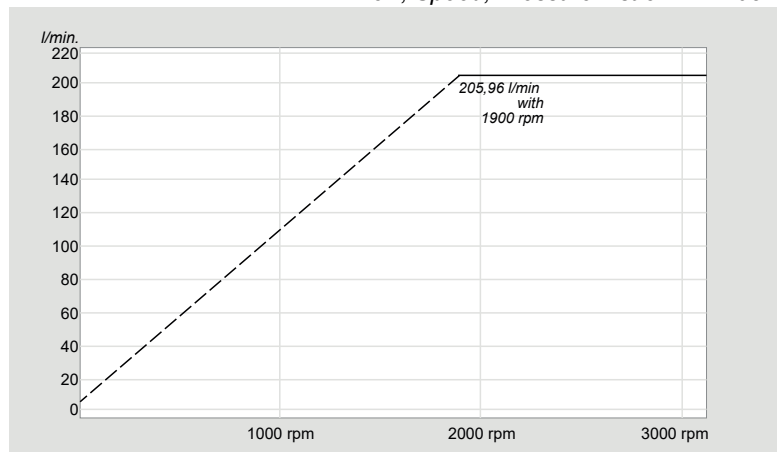

# 2PE 130 - SAE D - 4 BOLT

SAE D 13T-8/16  
SAE C 14T-12/24

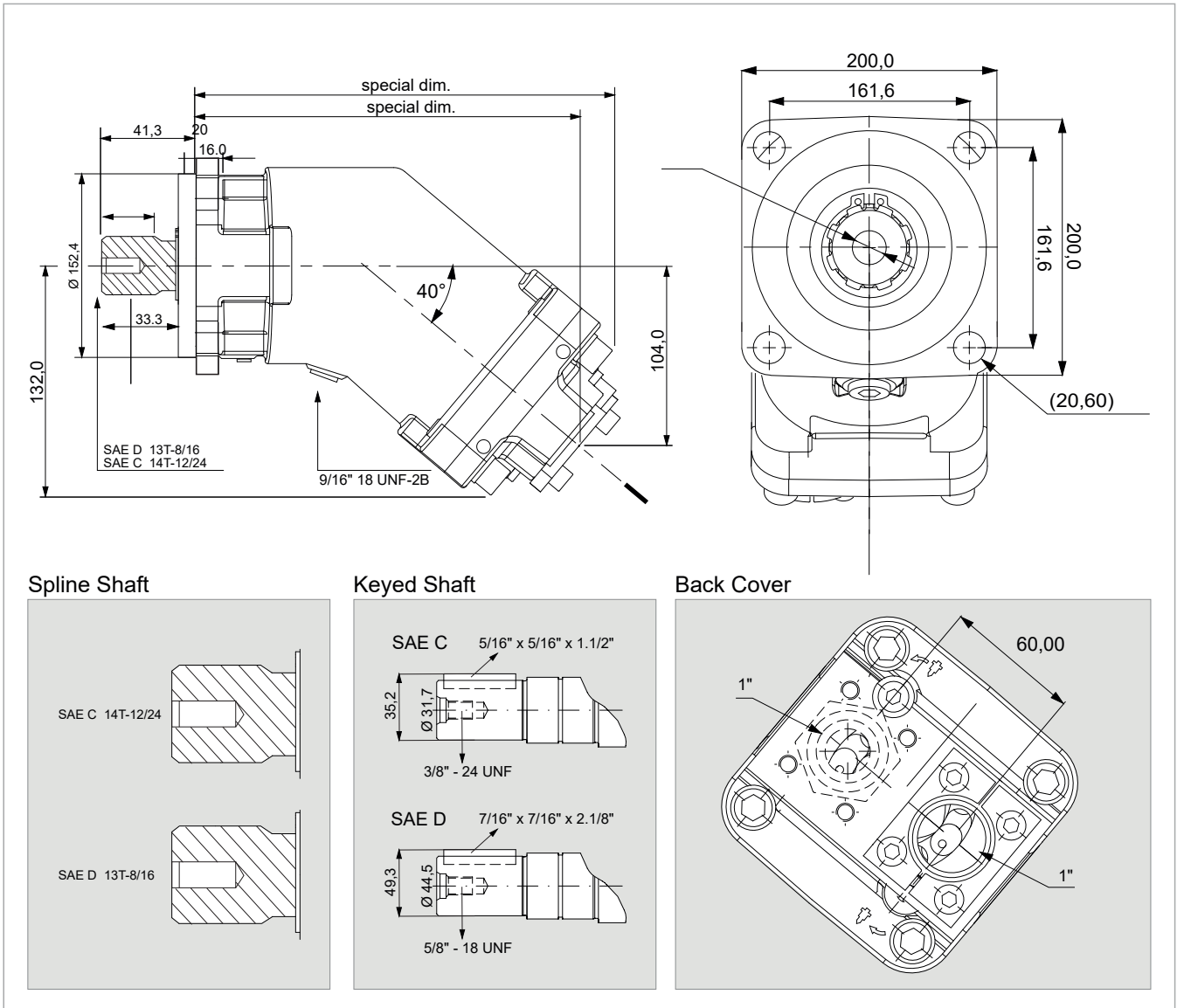

Spline Shaft

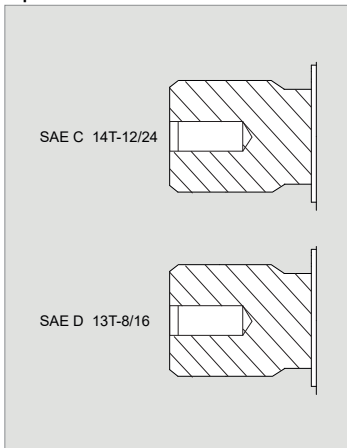

Keyed Shaft

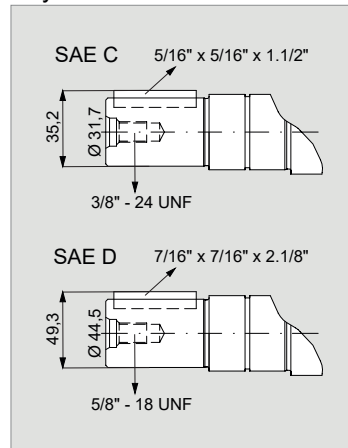

Back Cover

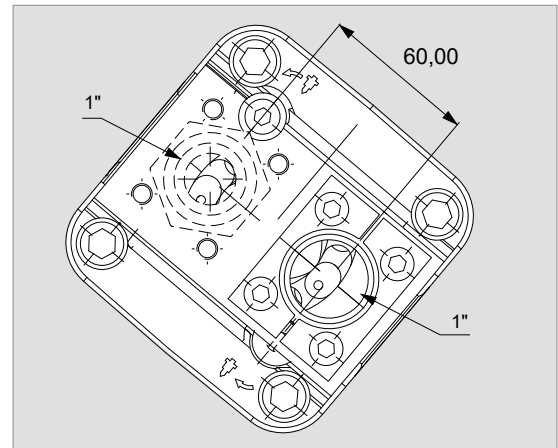

Flow, Speed, Pressure List of 2PE 130

<b>x 1000 rpm</b>	130,00 cc
<b>x 1500 rpm</b>	195,00 cc
<b>Max. Continuous Pump Speed</b>	1600 rpm
<b>Max. Limited Pump Speed</b>	1750 rpm
<b>Max. Continuous Pressure</b>	350 bar
<b>Max. Intermit. Peak Pressure</b>	400 bar
<b>Max. Torque at 350 bar</b>	746 Nm
<b>Weight without inlet fitting</b>	21,50 kg
<b>Weight with inlet fitting</b>	22,00 kg
<b>Rotation</b>	CW-CCW

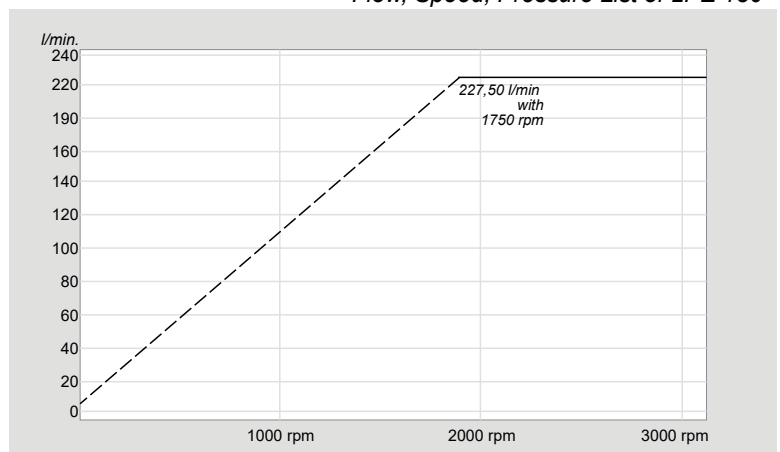

# Special Mounting Flanges

6 BOLT  
Mounting Flange

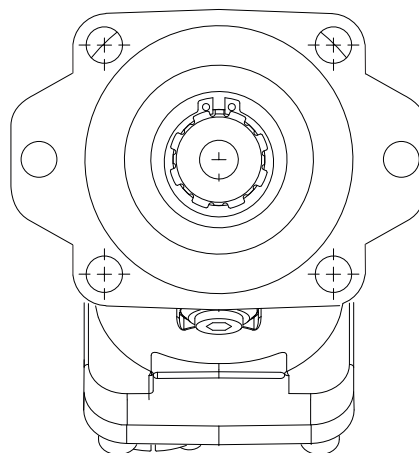
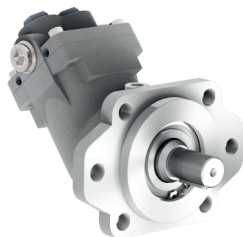

SAE B4 BOLT  
(SAE J744)

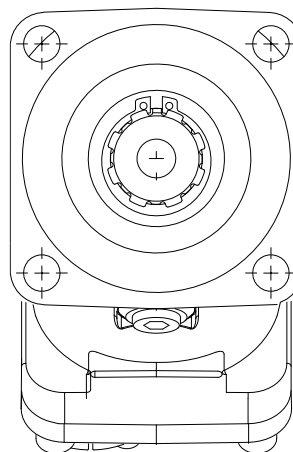
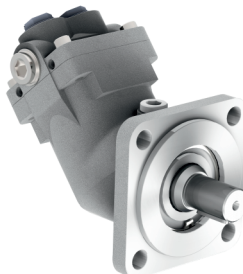

SAE B2 BOLT  
(SAE J744)

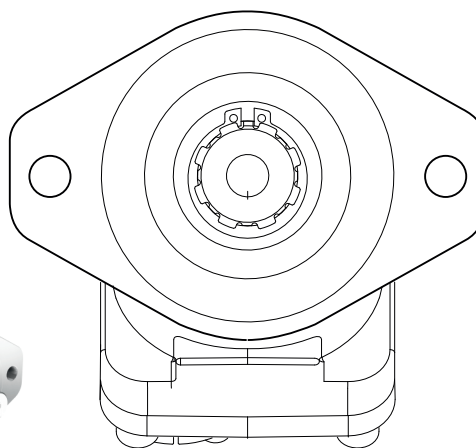
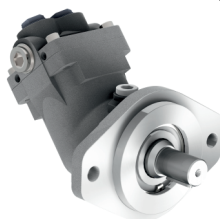

# Changing the Direction of Rotation

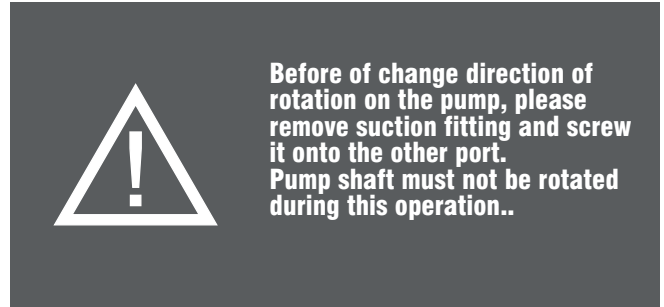
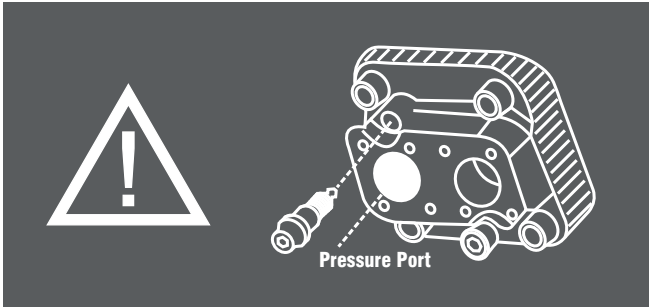

!! CHECK THE ROTATION FROM THE POWER TAKE OFF  
!! THE ROTATION DIRECTION OF THE PUMP

Left Default delivered. Right Change rotation.

## HOW TO CHANGE ROTATION OF THE 2PE PUMP;

- Remove the inlet fitting with split flange,
- Remove the setting screw,
- Remove the plug,
- Put the setting screw where the plug was,
- Put the plug where the setting screw was,
- Put seal on the inlet fitting, then the inlet fitting on the side where the plug is, and fix with the split flange,
- Tighten with the screws.

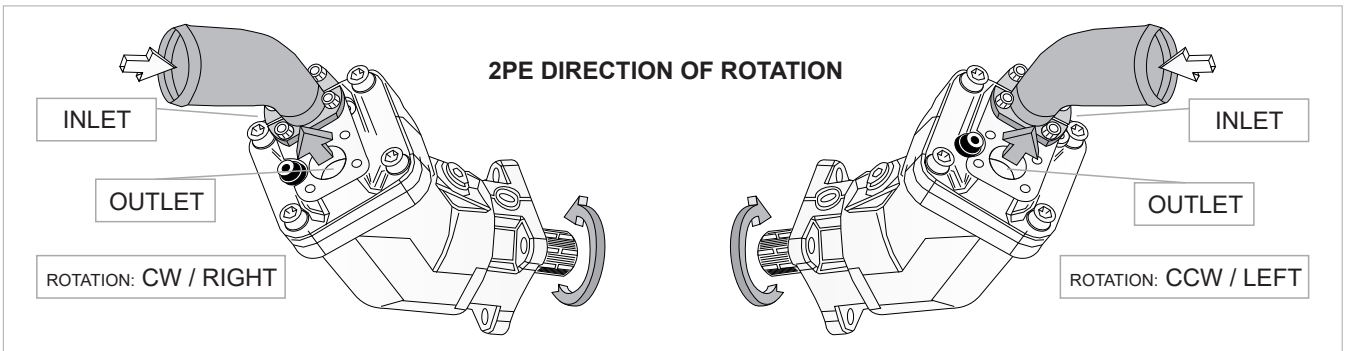
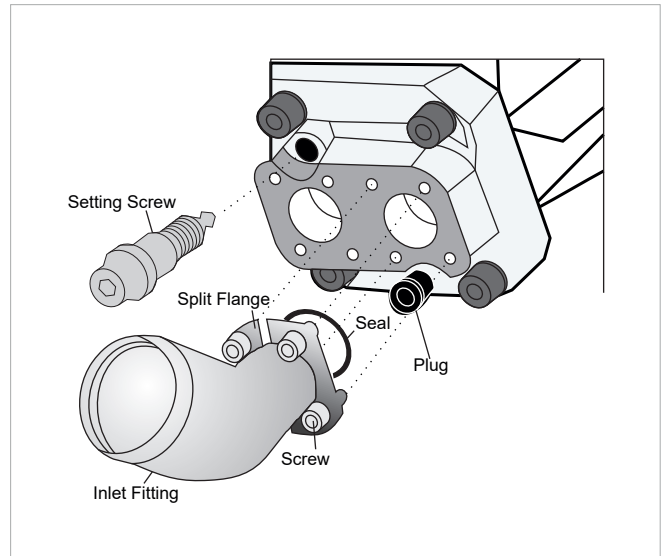

**NOTE I**  
The Inlet Fitting is pre-assembled on delivery and must be tightened to the torque specified for the thread size before installation.

**NOTE II**  
To change the direction of rotation of the 2PE Bent Axis Pump, you must change the pressure connection from to right port to the left port.

**NOTE III**  
If the pump drive shaft moves while making the change, the 2PE Bent Axis Pump may be damaged. After unscrewing the pressure connection, do not turn the drive shaft of the pump!

## FLUID

Please check the following recommendations:  
Mineral oil

<b>Viscosity</b>	20 to 40 cSt
<b>Min. viscosity</b>	5 cSt
<b>Viscosity for correct operation</b>	10 to 400 cSt
<b>Recommended filtration</b>	10µ absolute class 9 NAS 1638 class 6 SAE class 18/15 ISO
<b>Max temp.</b>	100° C



# Inlet Fittings, Accessories

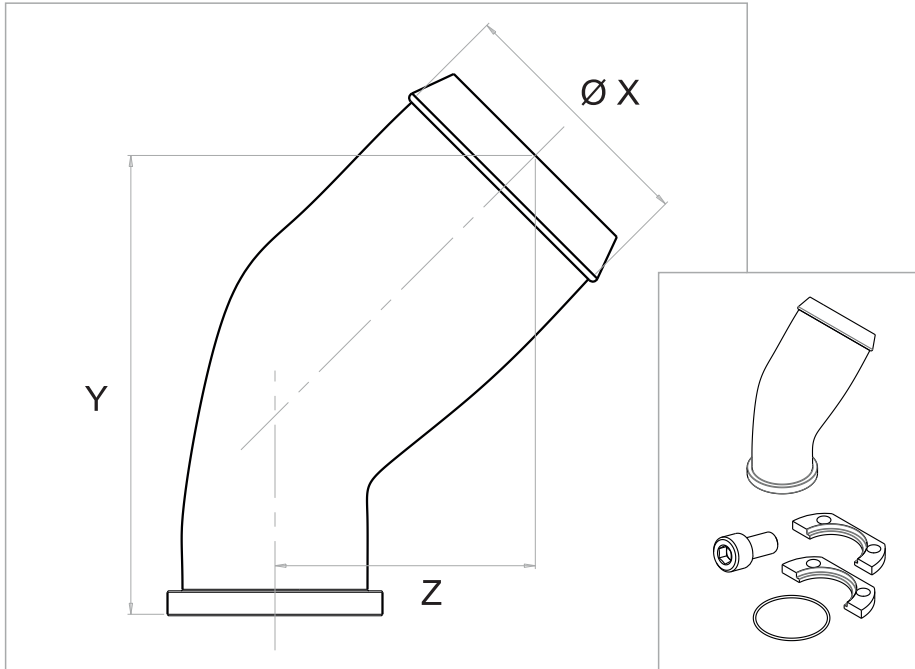

**45° elbow fittings**

Ø hose	1 1/2"	1 3/4"	2 1/2"
Ø X	39	46	64
Y	91	91	125
Z	46	46	62

**90° elbow fittings**

Ø hose	1 1/2"	2"	2 1/2"
Ø X	39	51	64
Y	58	64	71
Z	80	80	87

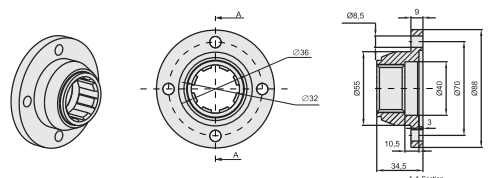
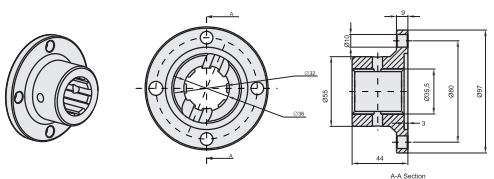
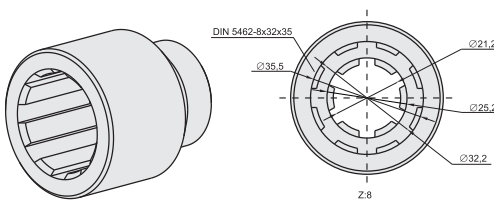
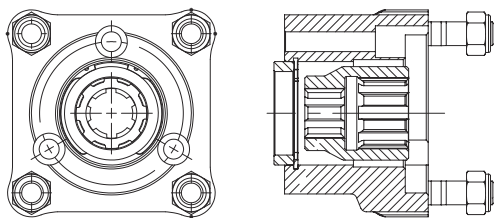

	<p><b>Inlet Fittings &amp; Installation Parts</b></p> <ul style="list-style-type: none"> <li>- Split Flange</li> <li>- Seal</li> <li>- Screw</li> </ul>
	<p><b>By-Pass Valves</b></p> <ul style="list-style-type: none"> <li>- 12 V</li> <li>- 24 V</li> </ul>
	<p><b>Hydraulic Adapters</b></p> <ul style="list-style-type: none"> <li>- PTO Piston Pump Adapter</li> <li>- PTO Gear Pump Adapter</li> <li>- Long / Short Adapter</li> </ul>
	<p><b>Flanges</b></p> <ul style="list-style-type: none"> <li>- 1120 ( 6 Spline )</li> <li>- 1120 ( 8 Spline )</li> <li>- 1300 ( 6 Spline )</li> <li>- 1300 ( 8 Spline )</li> </ul>
	<p><b>Couplers</b></p> <ul style="list-style-type: none"> <li>- 6 x 8 Couplar</li> <li>- 6 x 8 Couplar ( Long )</li> <li>- 8 x 8 Couplar</li> <li>- 8 x 8 Couplar ( Long )</li> </ul>

# Installation & User Guide

The 2PE pumps fitted with a rubber front seal.

## INSTALLATION

2PE pumps are direct mounting on the PTO.

Grease the splined shaft before installation. Do not tap the gear wheel/driver into position.

Remove any mounted screws on the pump.

The 2PE was delivered with protective covers and plastic/threaded plugs.

It should be removed before of install. Please check seals and surfaces. If sealing or other surfaces damaged please contact your responsible Service Partner.

Start up and run the pump at medium speed (800 to 1000 rpm at the PTO) until the oil flowing out of the pump. ( There are no more air bubbles.)

## OIL SUPPLY

Oil and supply line should be clean, and the supply line is airtight.

## SUCTION LINE

Connect the suction line, tighten the suction connection bolts in diametric pairs.

Connect the pressure line.

## REPAIR

We offers a comprehensive range of services for the repair of our Bent Axis Pumps.

Repairs to the 2PE Bent Axis Pump may only be performed by authorized, skilled and instructed personnel.

Only use original and pre-installed our 2PE spare parts from supplied to Manufacturer..

Tested and pre-installed 2PE pumps successful repair requiring only little time.

## SPARE PARTS

The spare parts list and the 2PE pump order specific.

When ordering spare parts, quote the material and complete Ordering code number of the 2PE Bent Axis Pump as well as the right numbers of the spare parts.

## RISK OF DAMAGE!

Do not touch the drive shaft of the 2PE Bent Axis Pump

Do not touch sensor, valves and fittings

Do not touch sealing surfaces.

## DIMENSIONS & WEIGHTS

Weight													
- Without inlet fitting	<b>kg</b>	8,00	10,00	10,00	10,50	11,50	11,50	12,00	12,50	12,50	16,00	16,50	21,50
- With inlet fitting	<b>kg</b>	8,45	10,40	10,40	10,90	11,90	11,90	12,40	12,90	12,90	16,40	16,90	22,00

Address all questions regarding spare parts to your responsible Our Service Partner or the technical service department of the manufacture's plant / factory for the 2PE Bent Axis Pumps.

ÇELEBİ HİDROCEL OTOM. SAN. TİC. LTD. ŞTİ.  
Fevzicakmak Mh. Aslım Cd. Kobisan San. Sit. H Blok No: 67J  
42050 Karatay – Konya / TURKEY  
Phone : +90 (332) 345 13 70 - +90 (332) 345 13 71  
hidrocel@hidrocel.com.tr

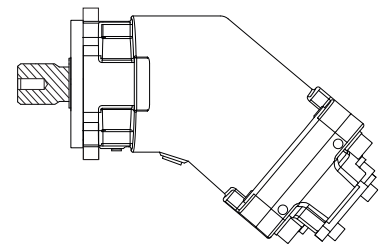

# Complete Product Range

## Piston Pumps

## Piston Motors

# DIN

DIN 5462 / ISO 14  
8x32x35  
8x32x36  
DIN 6885



**2PBA**



**2PBM**

# ISO

ISO 3019-2 (4 BOLTS)  
DIN 5480 -W25,30,35,40,45  
DIN 6885 -Ø20,25,30,35,40,45



**2PS**



**2PM**

# SAE

SAE B2 C4 - SAE D  
SAE J498b  
SAE J 744



**2PE**



**2PEM**

# Contact

## ÇELEBİ HİDROCEL OTOM. SAN. TİC. LTD. ŞTİ.

Fevzicakmak Mh. Aslım Cd. Kobisan San. Sit. H Blok No: 67J  
42050 Karatay – Konya / TURKEY

Phone : +90 (332) 345 13 70

+90 (332) 345 13 71

Fax : +90 (332) 345 13 72

hidrocel@hidrocel.com.tr

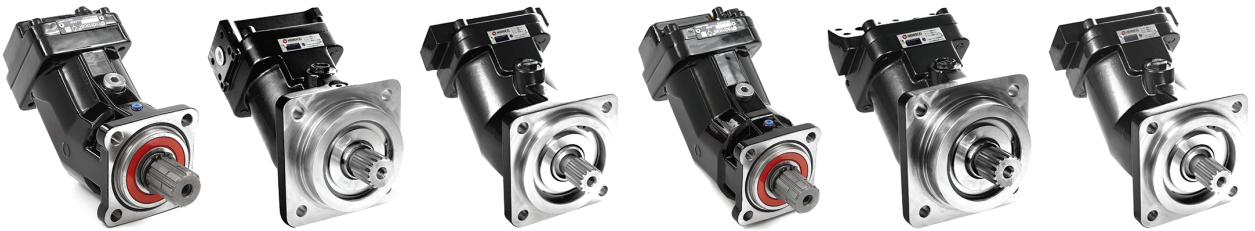

[www.hidrocel.com.tr](http://www.hidrocel.com.tr)